

CAN-AM®

CAN-AM

Mill and Drag Chain

SUPPLY SERVICES LTD

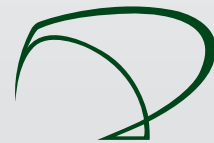

Phone 0800 102 112 - www.supplyservices.co.nz

CAN-AM Products

visit us at www.can-amchains.com

Chain Designation & Heat Treating.....1
 Offset Side Bar Welded Steel Chain.....2
 Straight Side Bar Welded Steel Chain.....3
 Extra Heavy Duty4
 Mill Chain Attachments5-9
 Side-Lift Log Chairs, UHMW FLTS10
 Log Cradles & Slasher Attachments11
 Roof Top & Roller Top Welded Steel12
 Drag Class Welded Steel Chain & Attachments13-18
 Malleable & Combination Chain.....19-20
 Power Transmission & Trimmer Chain.....21
 Trimmer Attachments22
 Trimmer Chain Roller Lugs/81X Roof Top.....23
 Mill Chain Rivets24
 OSB Chains & Apron Feed Chains25-28
 J Bar Sorter & Steel Pintle Chain29
 Long Link Chain & Attachments30-33
 Rivetless.....34-35
 CDM 142 Chain.....36-38
 CAN-AM Bearings.....39-43

TECHNICAL SECTION44-52

Welding Procedure44
 Lubrication & Break In.....45
 Installation & Operation46
 Reducing Maintenance Costs47
 Typical Layout Configurations49
 Long Link Conveyors51
 Terms & Conditions.....52

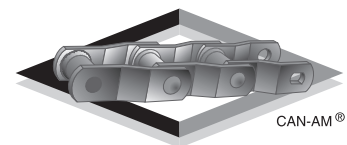
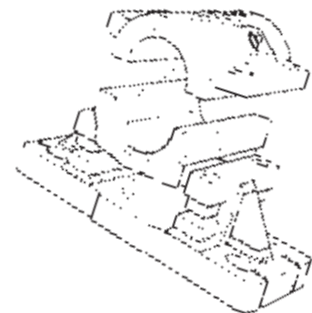
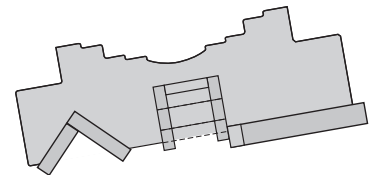
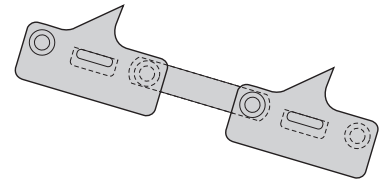

CHAIN DESIGNATION

Due to increasing demand from our customers and our commitment to serving the industry, we have broadened our selection base and to achieve this effectively, we have adopted the following National Standard Chain Designation:

- WR – Welded steel chain c/w heat treated rivets
- WH – Welded steel chain – fully heat treated
- WHIBR – Fully heat treated plus further Induction Hardened Barrels & Rivets
- WHIBRS – Same as IBR **plus** sidebar wear surfaces
- WD – Welded steel drag chain
- XHD – Extra heavy duty
- CS – Cast steel barrel

NOTE:

Unless otherwise specified (quoted) welded steel chains are always supplied in 10 ft. lengths.

THROUGH HEAT TREATING & INDUCTION HARDENING

(IBR) denotes fully heat treated & induction hardened barrels & rivets.

(IBRS) denotes fully heat treated & induction hardened barrels, rivets & side bars.

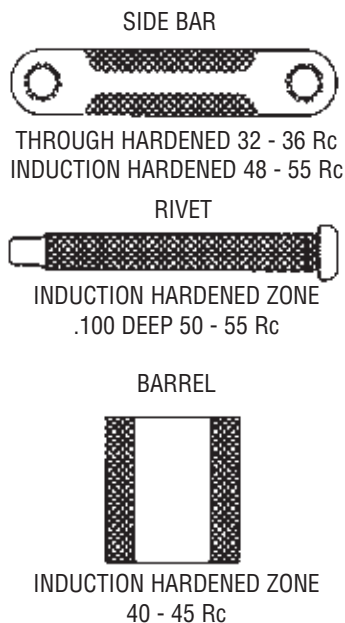

Used individually or combined the two types of heat treating CAN-AM chain can dramatically increase chain life.

Impact & Strength

Through heat treated chain (to the proper hardness) will improve impact and ultimate strength.

Wear

In a non-abrasive environment **heat treated chain** will give up to 50% greater wear life. Reduction of elongation of side bar holes can be assisted by induction hardening the hole perimeter.

In a non-abrasive environment, **induction hardened chain** will give several times greater wear life.

Note: Individual situations may vary wear life.

Induction hardening depth and Rc range will vary to suit thickness of material, diameter of rivets and particular applications.

HEAT TREATED AND INDUCTION HARDENED CHAIN

CAN-AM welded steel chains are available from stock with fully heat treated parts and/or induction hardened parts.

For maximum chain life in severe applications including heavy impact loading, high speed requirements, capacity loads, or abrasive conditions, some or all of your CAN-AM chain will benefit from specific heat treatment.

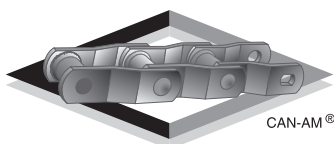

SUPPLY SERVICES LTD 
 Phone 0800 102 112 - www.supplyservices.co.nz

OSB CHAINS

CAN-AM CHAINS manufactures a full range of chain products especially for the OSB Industry. Many of these are proprietary designs developed for specific applications.

Corrosion, shock loading, fatigue and wearability are common problems that we have generated solutions for.

Consult your "CAN-AM CHAINS" factory representative for details.

LOG DECK CONVEYORS

BARKER INFEED CONVEYORS

HOT POND CONVEYORS

LOG TRANSFER CONVEYORS

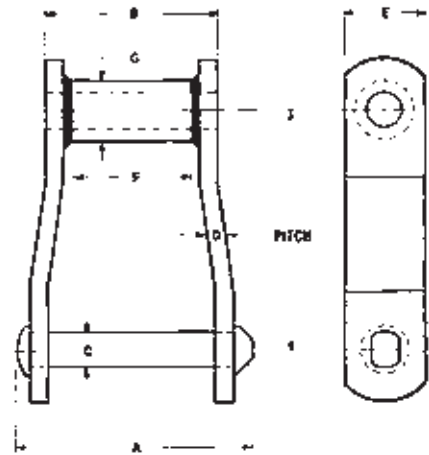

Chain Number	Average Pitch in Inches	Ultimate Strength lbs.	Allowable Working Load lbs.	Links per Foot	Average Weight per Foot lbs.	Approx. Overall Width	Length of Bearing	Rivet Dia.	Side Bar Thickness	Side Bar Height	Approx. Tooth Face at Pitch Line	Outside Barrel Dia.
WH-124 IBR	4.000	57,000	9,500	3	7.8	4 1/4	2 3/4	3/4	3/8	1 1/2	1 1/2	1 1/4
WH-124XHD IBR	4.063	122,000	20,400	3	14.6	4 7/8	3	1	1/2	2	1 1/2	1 5/8
WH-106XHD IBR	6.050	122,000	20,400	2	11.8	4 7/8	3	1	1/2	2	1 1/2	1 5/8
WH-132 IBR	6.050	122,000	20,300	2	14.1	6 3/8	4 13/32	1	1/2	2	2 3/4	1 3/4
WH-132XHD IBR	6.050	122,000	20,400	2	15.3	6 3/4	4 21/32	1	5/8	2	2 3/4	1 3/4
WH-150 IBR	6.050	122,000	20,400	2	16.3	6 1/2	4 13/32	1	1/2	2 1/2	2 3/4	1 3/4
WH-155 IBR	6.050	175,000	29,000	2	19	6 13/32	4 7/16	1 1/8	9/16	2 1/2	2 3/4	1 3/4
WH-157 IBR	6.050	185,000	30,000	2	20.0	6 3/4	4 5/8	1 1/8	5/8	2 1/2	2 3/4	1 3/4
WH-200 IBR	6.125	190,000	32,000	2	22.1	6 3/4	4 5/8	1 1/4	5/8	2 1/2	2 3/4	1.9
WH-159 IBR	6.125	210,000	35,000	2	23	6 3/4	4 5/8	1 1/4	5/8	3	2 3/4	1.9

All above chains are fully through hardened with further deep induction hardened rivets and barrels. See page 1 for technical specs.

RAKEBACK CONVEYORS

Chain Number	Average Pitch in Inches	Ultimate Strength lbs.	Allowable Working Load lbs.	Links per Foot	Average Weight per Foot lbs.	Approx. Overall Width	Length of Bearing	Rivet Dia.	Side Bar Thickness	Side Bar Height	Approx. Tooth Face at Pitch Line	Outside Barrel Dia.
WH-82XHD IBR	3.075	57,400	8,400	3.9	8.5	3 15/16	2 3/8	3/4	3/8	1 1/2	1 1/8	1 1/4
WH-124 IBR	4.000	57,000	9,500	3	7.8	4 1/4	2 3/4	3/4	3/8	1 1/2	1 1/2	1 1/4
WH-106 IBR	6.000	60,000	10,000	2	6.2	4 1/4	2 3/4	3/4	3/8	1 1/2	1 1/2	1 1/4
WH-144 IBR	4.000	85,000	14,200	3	12.5	4 5/16	2 3/4	1	3/8	1 3/4	1 1/2	1 5/8
WH-166 IBR	6.000	85,000	14,200	2	11.7	4 1/4	2 3/4	1	3/8	1 3/4	1 1/2	1 5/8
WH-124XHD IBR	4.063	122,000	20,400	3	14.6	4 7/8	3	1	1/2	2	1 1/2	1 5/8
WH-106XHD IBR	6.050	122,000	20,400	2	11.8	4 7/8	3	1	1/2	2	1 1/2	1 3/4
WH-132 IBR	6.050	122,000	20,400	2	14.1	6 1/2	4 13/32	1	1/2	2	2 3/4	13/14

All above chains are fully through hardened with further deep induction hardened pivots and barrels. See page 1 for technical specs.

OSB CHAINS

SPECIAL SLOTTED A22 FOR RAKEBACK

Chain Number	A	B	C	D	E	F	G	H
WH-124 IBR	4	5 15/16	1 3/4	2	13/16	1 1/2	1 1/2	1/2
WH-124XHD IBR	4 1/8	6 1/16	1 3/4	2	13/16	1 1/2	2	1/2
WH-106 IBR	4	5 15/16	1 3/4	2	13/16	1 1/2	1 1/2	1/2
WH-106XHD IBR	4 1/8	6 1/16	1 3/4	2	13/16	1 1/2	2	1/2
WH-132 IBR	4 1/2	6 1/4	3	2	13/16	1 1/2	2	1/2
WH-132 XHD IBR	4 5/8	6 3/8	3	2	13/16	1 1/2	2	1/2
WH-144 IBR	4	5 15/16	2	2 1/2	13/16	1 5/16	1 3/4	1/2
*WH-166 IBR	4	5 15/16	3	3	13/16	1 5/16	1 3/4	1/2
*WH-166 IBR (Option)	3 3/4	5	3	2 1/2	11/16	1	1 3/4	1/2
					OR 3/4			

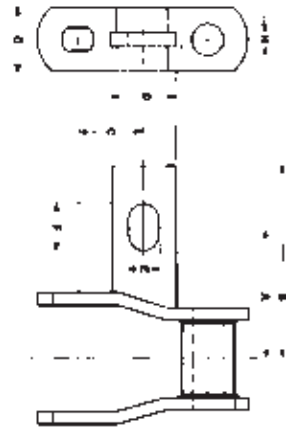

All above have Through Hardened Sidebars, Through Induction Hardened Barrels and Through & Induction Hardened Rivets

SPECIAL CHAINS

APRON FEEDER

RS 933-F

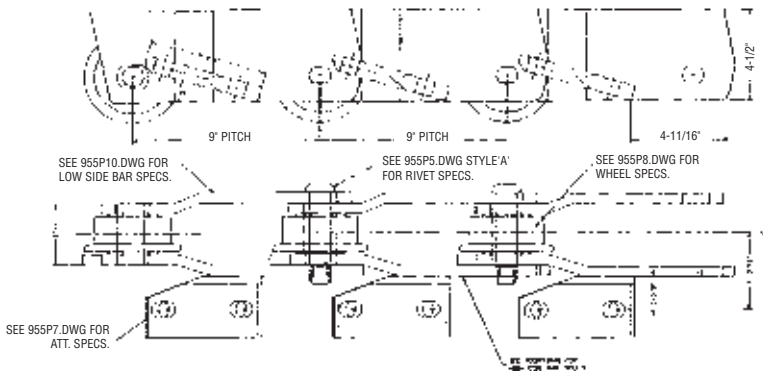
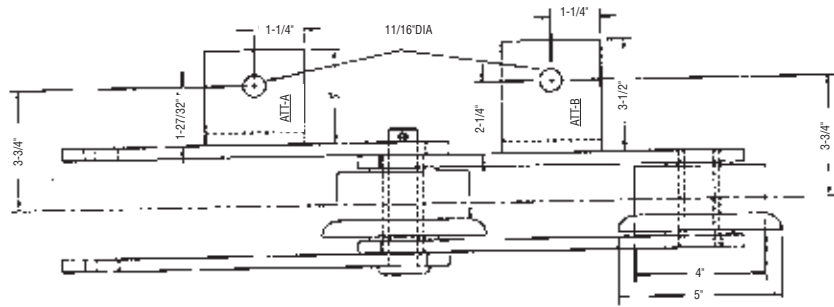

RS 944
HD Pan Chain
CAM 955 PI

250MM

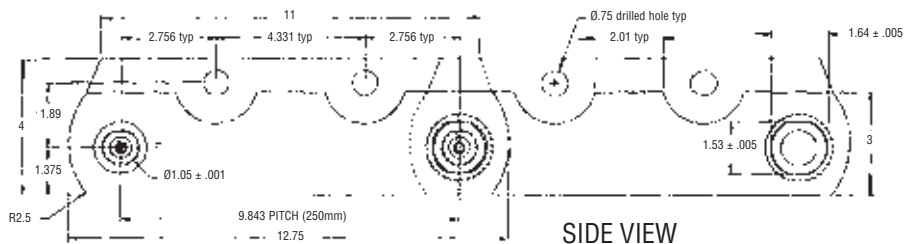
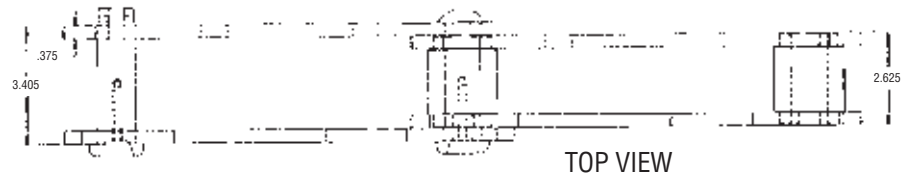

ENGINEERED CLASS CHAIN

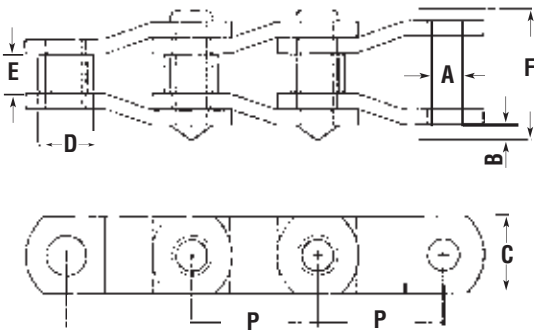

Style 1 (Roller)

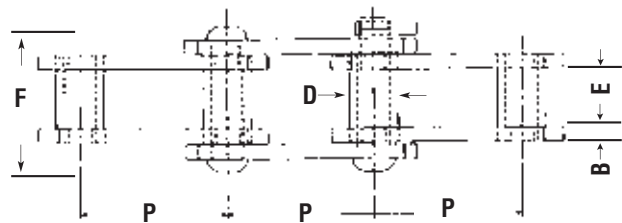

Style 2 (Bushed)

Chain Number	Style	P Pitch	WT/Foot	Ult. STGH	A	B & C	D	E	F
					Pin. Diameter	Side Bar	Barrel/ Roller Diameter	Max Sprocket Face	Width
SB2512	1	3.067	13.2	110,000	.750	3/8 X 2 1/4	1.62	1.50	3.9
SB3011	1	3.067	13.2	110,000	.750	3/8 X 2 1/4	1.62	1.50	3.9
SB1242	1	4.063	15.6	140,000	.875	1/2 X 2 1/4	1.75	1.9	4.8
SB1245	1	4.073	18.6	170,000	.9375	9/16 X 2 3/8	1 25/32	1.9	5.1
SB1254	1	4.060	18.6	170,000	.9375	1/2 X 2 1/4	1.78	1.2	4.25*

*Note: Can also be flush welded rivets at 3 3/8 OAW.

Commonly used sizes shown. Consult your CAN-AM Representative for other sizes.

160 MM SPECIAL

Comes with A-2 L & RH
CAM 531 PI

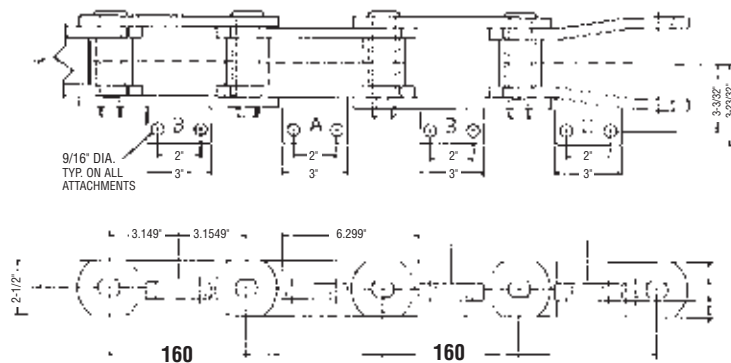

S 1209

Comes with A-2 Attachment
CAM 0465

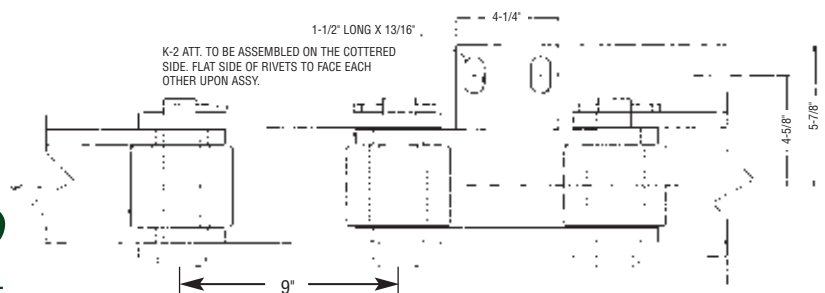

SUPPLY SERVICES LTD
Phone 0800 102 112 - www.supplyservices.co.nz

BUCKET ELEVATOR CHAIN

HB BUSHED CHAIN

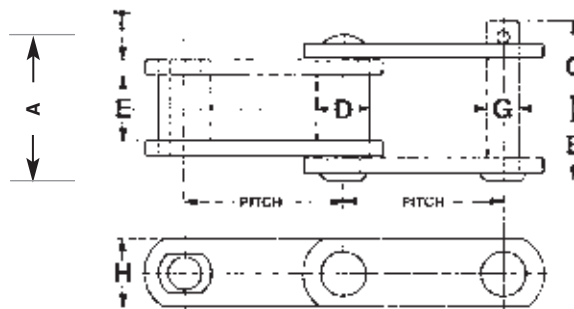

Chain No.	Pitch	Width				Bushing		Pin		Side Bar			Avg. Ult. Strength lbs	Max. Work Load lbs	Avg. Wt. Per ft./lbs
		Overall A	Pin Head to CL. B	Pin End to CL. C	Inside E	Diam. D	Mat'l. ③	Diam. G	Mat'l. ③	Height H	Thick T	Mat'l. ③			
SB850	6.000	5 3/4	2 7/8	3 5/16	2 1/4	2	ACH	1 5/16	AIH	3	5/8	CHT	200,000	25,000	23.5
856	6.000	6 1/8	2 7/8	3 1/4	3	1 3/4	ACH	1	AIH	2 1/2	1/2	CHT	100,000	14,000	16.5
857	6.000	6 1/8	2 7/8	3 1/4	3	1 3/4	ACH	1	AIH	3 1/4 ^④	1/2	CHT	130,000	14,000	21.0
859	6.000	7 3/8	3 9/16	3 13/16	3 3/4	2 3/8	ACH	1 1/4	AIH	4 ^⑤	5/8	CHT	200,000	21,800	34.0

③ Material:

- CHT – Carbon Heat Treated
- CCH – Carbon Case Hardened
- AIH – Alloy Steel Induction Hardened
- ACH – Alloy Case Hardened

④ Outer plain side bars are 2 1/2" high

⑤ Outer plain side bars are 3" high

HB BUSHED CHAIN ATTACHMENTS

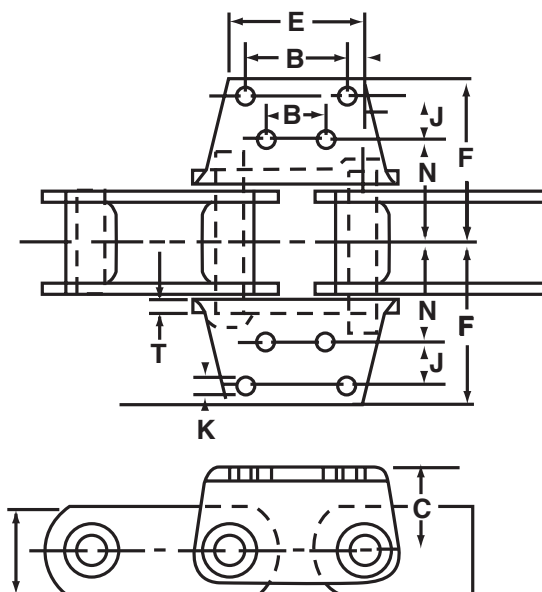

Attach. No.	Chain No.	A	B	B'	C	E	F	J	Bolt Diam. K	N	T	Avg. Wt. per FT/LBS
K44	857	3 1/2	3 1/2	3 1/2	2 1/2	6 1/4	6 27/32	2 1/2	1/2	—	1/2	42.0
	859	4 1/2	4 1/2	2 3/4	3	6 1/2 ^⑥	7 35/64	2	5/8	—	5/8	67.0

⑥ With attachments on pin link

SUPPLY SERVICES LTD 
 Phone 0800 102 112 - www.supplyservices.co.nz

FORMED STEEL PINTLE

STEEL PINTLE CHAIN

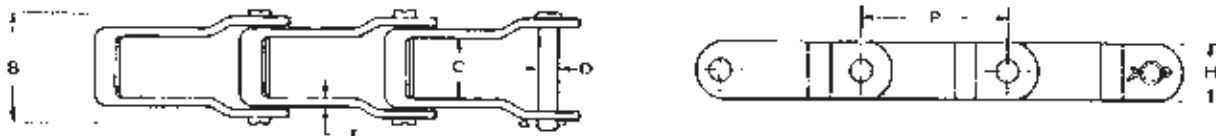

662, 667H, 667J, 667X, 667XC, 667K, 667KC, 667XH, 88K

Chain Size	Links per 10'	Weight per 10'	Min. Adv. Tensile Strength	Pitch 'P'	Pin Dia. 'D'	Inside Width 'C'	Height 'H'	Thickness 'C'	Overall Width B
662	72	10.5 lbs.	8,500 lbs.	1.664	.281	29/32	.720	.125	1 5/8
667H	52	11.7 lbs.	9,500 lbs.	2.313	.312	1	.875	.125	1 47/64
667X	53	18.6 lbs.	21,000 lbs.	2.25	.437	1 1/16	.937	.170	1 61/64
667XC	53	21.0 lbs.	18,000 lbs.	2.250	.437	1 1/16	.937	.170	1 61/64
667K	53	24.4 lbs.	20,000 lbs.	2.250	.437	1 5/64	1.062	.200	2 1/8
667KC	53	25.6 lbs.	24,000 lbs.	2.250	.437	1 5/64	1.062	.200	2 1/8
667XH	53	28.0 lbs.	28,000 lbs.	2.25	.469	1 5/64	1.062	.224	2 5/16
88K	46	23.0 lbs.	20,000 lbs.	2.609	.437	1 5/64	1.062	.200	2 1/8

'J' BAR SORTER CHAIN

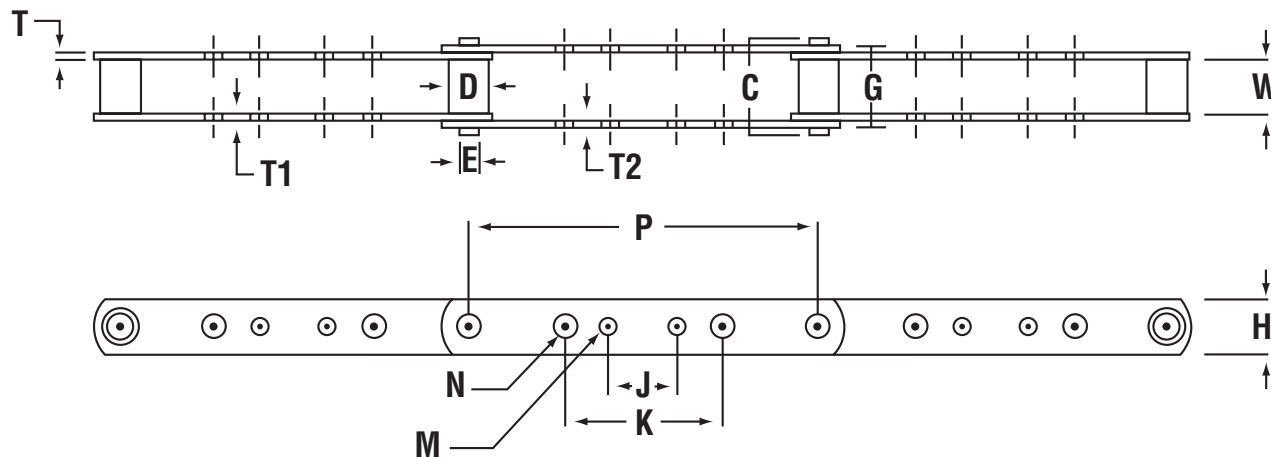

Chain No.	Links in 10' or 3048 mm	Weight lbs. per 10' (Kg per metre)	Avg. ultimate strength lbs. (kN)	P Pitch In. (mm)	C In. (mm)	D In. (mm)	E In. (mm)	G In. (mm)	H In. (mm)	J In. (mm)	K In. (mm)	M In. (mm)	N In. (mm)	W In. (mm)	T1 In. (mm)	T2 In. (mm)
3939*	15	15.5 (2.3)	24,000 (107)	8.000 (203.20)	1.93 (49.02)	.900 (22.86)	.432 (11.00)	1.74 (44.20)	1.125 (28.58)	1.50 (38.10)	3.62 (91.95)	.28 (7.14)	.41 (10.32)	1.06 (26.92)	.155 (3.94)	.155 (3.94)
3939-4	15	15.5 (2.3)	24,000 (107)	8.000 (203.20)	1.93 (49.02)	.900 (22.86)	.432 (11.00)	1.74 (44.20)	1.125 (28.58)	1.50 (38.10)	4.00 (101.60)	.28 (7.14)	.28 (7.14)	1.06 (26.92)	.155 (3.94)	.155 (3.94)
3939-H	15	24.0	37,000	8.000	2.3	.900	.432	2.00	1.125	1.50	4.00	.28	.28	1.06	.250	.250

* Sometimes referred to as 81X-8.

ALLOY STEEL LONG LINK CHAIN

This type of chain is designed to operate over a sprocket wheel and is largely used in sawmills for conveying logs, slabs, sawdust, etc. It can be supplied to the dimensions shown in the following table, or to other dimensions which may be specified on order. Each link is made to a specified inside length (pitch) and width to provide for correct operation of the chain over the teeth of the sprocket.

This chain is normally supplied with refuse conveyor flights, commonly called skookum flights. These attachments may be installed at our plant, or shipped separately for your installation on the job site.

Cast steel tang flights, UHMW tang flights and UHMW bar flights are also available.

The advantages of using Alloy Long Link chain are as follows:

- for use where the properties of alloy steel fully heat treated, can save on down time and replacements costs compared to chains of lesser quality.
- extremely high hardness value.
- reduced elongation problem.
- resistant to shock loading, grain growth, and work hardening.
- less reduction in strength when used at temperatures up to 700° F. than other grades of chain tested.
- not subject to brittle fracture at low temperatures.

Note: We recommend that new sprockets be installed with new chain.

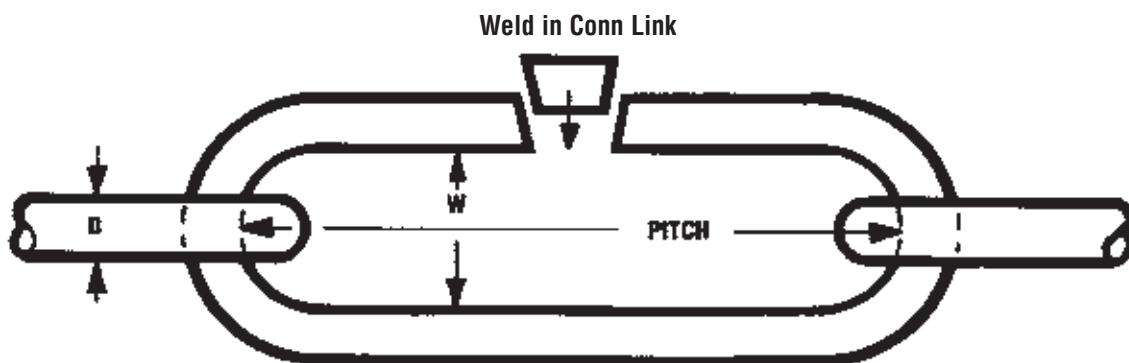

LAP LINK



Diameter	Inside Width	Inside Length	Minimum Breaking Load lbs.	Proof Test Load lbs.	Weight per Foot lbs.	
D	W	Pitch				
3/4	1 1/2	6	69,500	32,200	4.15	
7/8	1 1/2	6	93,500	40,200	5.90	
1	1 1/2	6	122,000	54,100	7.70	
1	1 3/4	6	122,000	54,100	7.90	*
1 1/8	1 1/2	6	143,000	62,300	10.00	
1 1/8	1 3/4	6	143,000	62,300	10.25	
1 1/8	2	6	143,000	62,300	10.50	*
1 1/4	2	6	180,000	80,500	13.00	
1 1/2	2 1/4	8	244,000	112,000	17.50	

All weights shown are approximate.

* Indicates sizes normally supplied from stock.

SUPPLY SERVICES LTD 
 Phone 0800 102 112 - www.supplyservices.co.nz

FABRICATED STEEL SKOOKUM FLIGHTS

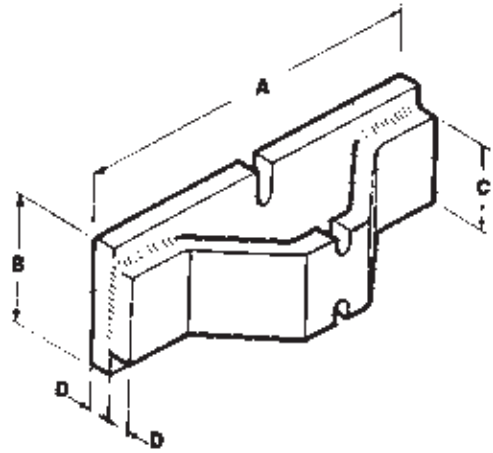
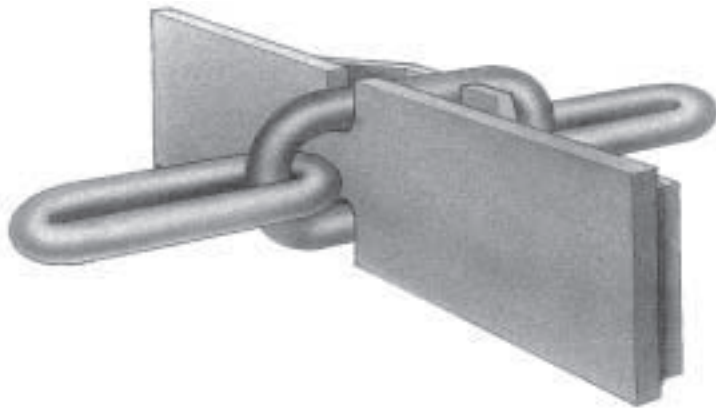

Available with UHMW face.

Chain Size								
3/4 x 1 1/2 x 6	A	12	14	16	18	20	22	24
	B	3	3	3	3	3	3	3
	C	2 1/2	2 1/2	2 1/2	2 1/2	2 1/2	2 1/2	2 1/2
	D	5/8	5/8	5/8	5/8	5/8	5/8	5/8
	Weight	12.59	14.52	16.48	18.44	20.38	22.32	24.26
7/8 x 1 1/2 x 6	A	12	14	16	18	20	22	24
	B	4	4	4	4	4	4	4
	C	3	3	3	3	3	3	3
	D	5/8	5/8	5/8	5/8	5/8	5/8	5/8
	Weight	14.90	17.19	19.47	21.76	24.04	26.32	28.60
1 x 1 1/2 x 6	A	12	14	16	18	20	22	24
	B	4	4	4	4	4	4	4
	C	3	3	3	3	3	3	3
	D	3/4	3/4	3/4	3/4	3/4	3/4	3/4
	Weight	17.88	20.62	23.36	26.10	28.84	31.58	34.32
1 x 1 3/4 x 6	A	12	14	16	18	20	22	24
	B	4	4	4	4	4	4	4
	C	3	3	3	3	3	3	3
	D	3/4	3/4	3/4	3/4	3/4	3/4	3/4
	Weight	19.13	22.10	25.08	28.05	31.09	34.01	36.99
1 1/8 x 1 1/2 x 6	A	12	14	16	18	20	22	24
1 1/8 x 1 3/4 x 6	B	4	4	4	4	4	4	4
1 1/8 x 2 x 6	C	3	3	3	3	3	3	3
	D	3/4	3/4	3/4	3/4	3/4	3/4	3/4
	Weight	19.13	22.10	25.08	28.05	31.09	34.01	36.99

SUPPLY SERVICES LTD 
 Phone 0800 102 112 - www.supplyservices.co.nz

CAST STEEL TANG FLIGHTS

Also available in UHMW

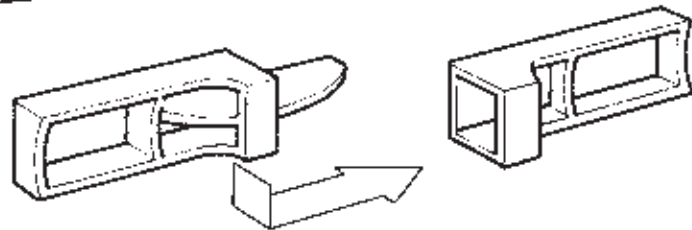
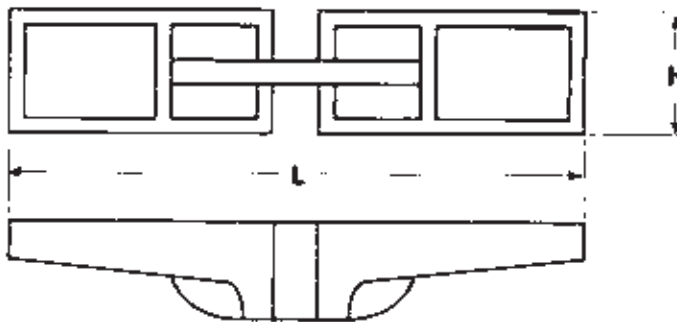
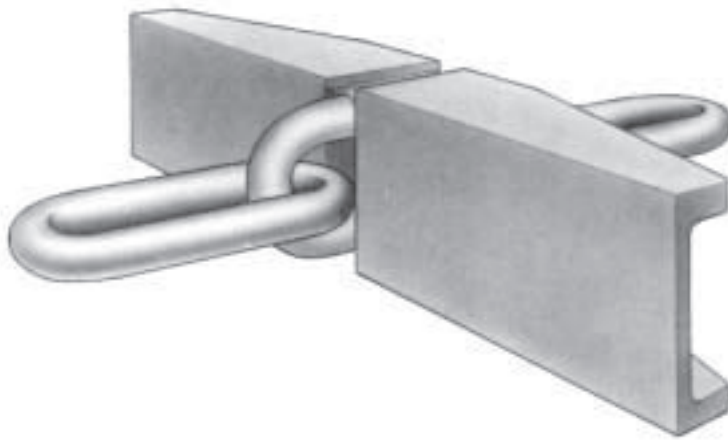

Chain Size																
3/4 x 1 1/2 x 6	Length	12	14	15	16	17	18	19	20	22	24					
7/8 x 1 1/2 x 6	Height	4	4	4	4	4	4	4	4	4	4					
1 x 1 1/2 x 6	Weight	15	17	18	19	20	21	22	23	25	27					
1 x 1 3/4 x 6	Length	12	14	15	16	17	18	19	20	21	24	26	28	30	32	34
1 1/8 x 1 3/4 x 6	Height	4	4	4	4	4	4	4	4	4	4	4	4	4	4	4
1 x 1 1/2 x 6	Weight	16	18	19	20	21	22	23	24	26	28	30	32	34	36	38
1 1/8 x 1 3/4 x 6	Length				16	17	18	19	20	22	24	26	28	30	32	34
1 1/8 x 2 x 6	Height				4 1/2	4 1/2	4 1/2	4 1/2	4 1/2	4 1/2	4 1/2	4 1/2	4 1/2	4 1/2	4 1/2	4 1/2
1 1/4 x 2 x 6	Weight				28	29	30	31	32	34	36	38	40	42	44	46
1 1/8 x 1 3/4 x 6	Length						18	19	20	22	24	26	28	30	32	34
1 1/8 x 2 x 6	Height						5	5	5	5	5	5	5	5	5	5
1 1/4 x 2 x 6	Weight						38	39	40	42	44	46	48	50	52	54

5" Tang Type will not fit in 1 1/2" wide long link chains

UHMW CONVEYOR FLIGHTS FOR LONG LINK CHAIN

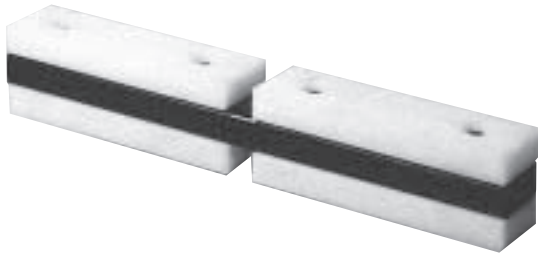

FLAT BAR

- 4" and 5" heights
- 16" to 36" lengths
- bolts to standard long link chains
- extra strength due to 1" flat bar
- easy to install
- longer life



ADVANCED DESIGN FEATURES

- recessed truss flat bar to eliminate bolt shear. This feature reduces flight bending under normal operating conditions and during a jam up situation
- available in 4" and 5" heights
- fits all sizes of round and square link chain
- sizes from 18" to 36" lengths
- five bolt assembly for added strength — all bolts are grade 5 c/w Nyloc nuts and hardened flat washers
- all common sizes stocked
- quick and easy installation

Because of its light weight and self-lubricating qualities, UHMW conveyor flight will reduce the drag on your conveyor system — requiring less power to operate. It reduces wear on the conveyor trough, and will greatly reduce noise level problems.

OTHER SPECIAL FLIGHTS ARE ALSO AVAILABLE

SUPPLY SERVICES LTD 
 Phone 0800 102 112 - www.supplyservices.co.nz

RIVETLESS CHAIN

STANDARD CHAIN

X-STYLE

- P = Chain Pitch
- B = Width of centre link opening
- D = Pin Diameter
- F = Chain Height
- L = Chain width over pins
- T = Sidebar Thickness
- X = Centre link width
- X_a = Centre link width - secondary

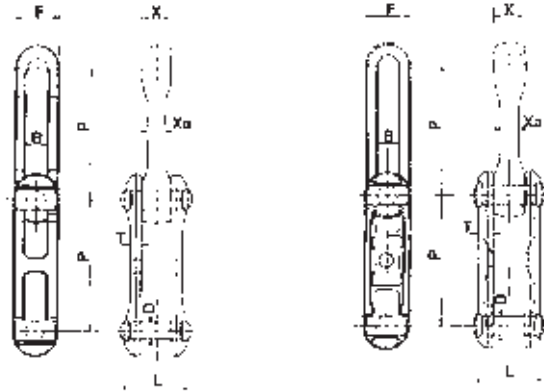

Chain	P Reference Pitch	B Min.	D	F Max.	L Max.	T	X	X _a	Number of Pitches/ft.
X-348	3"	.531	.50	1.078	1.75	.40	.75	.50	4
X-458	4"	.66	.63	1.43	2.25	.47	1.00	.63	3
468	4"	.84	.75	1.88	3.34	.63	1.63	1.13	3
X-658	6"	.66	.63	1.41	2.25	.48	1.02	.63	2
X-678	6"	.97	.87	2.00	3.13	.75	1.28	.84	2
698	6"	1.19	1.12	2.69	3.75	.85	1.56	1.00	2
998	9"	1.19	1.12	2.69	3.75	.88	1.56	1.00	1 1/3
9118	9"	1.45	1.38	3.13	4.88	1.25	1.94	1.31	1 1/3
9148	9"	1.91	1.75	3.78	5.85	1.38	2.47	1.63	1 1/3

RIVETLESS CHAIN ATTACHMENTS

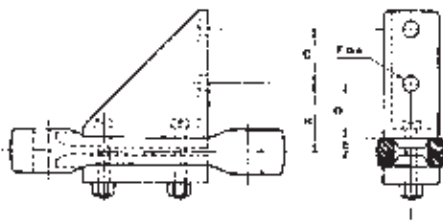

STYLE 3 S-22

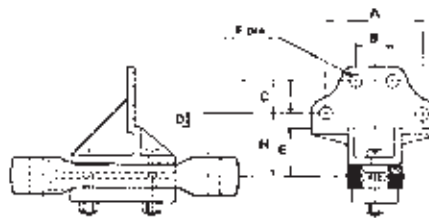

STYLE 1 S-2A

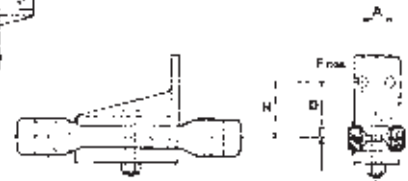

STYLE 2 S-2

Chain Size	Style	Part No.	A	B	C	D	E	F Bolt Dia.	H	Weight	Material* Each
458	3	4S2B			2	1 15/16	5/16	1/2	2 1/4	1.46	M.I.
468	2	4S2A	1 1/2			2 1/16	9/16	1/2	2 5/8	1.05	M.I.
468	3	4S2D			2	2 3/16	9/16	1/2	2 3/4	1.63	M.I.
678	2	6S2A	1 1/2			3	13/32	5/8	3 13/32	2.50	M.I.
678	1	6S2D	5 3/16	2 1/8	1 3/4			1/2	3 15/32	4.64	M.I.
678	3	6S2BK			2 1/4	2 9/16	13/32	5/8	2 31/32	3.32	M.I. & C.S.
698	3	6S2W			2 1/2	3 1/2	1/2	3/4	4	4.25	M.I. & C.S.
998	3	9S22			3	2 3/4	1/2	3/4	3 1/4	8.00	M.I.
998	1	9S2A	5 3/16	2 1/8	1 3/4	1 7/16	2 1/2	1/2	3 15/16	8.10	M.I.
998	3	9S2D			6 7/16	3 1/2	1/2	5/8	4	10.50	M.I.
9118	3	9S2F			6 1/2	3 9/16	11/16	3/4	4 1/4	12.00	M.I.
9148	3	9S2C			6 7/16	3 11/16	13/16	3/4	4 1/2	12.10	C.S.

*M.I. - Malleable Iron
C.S. - Cast Steel

Tabular dimensions and weights are approximate and non-binding. Design improvements may result in variations to published figures. Verification is recommended. © 1994 CAN-AM Chains, all rights reserved.

RIVETLESS CHAIN

F-2 ATTACHMENTS

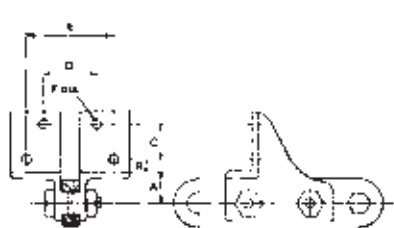

STYLE 1

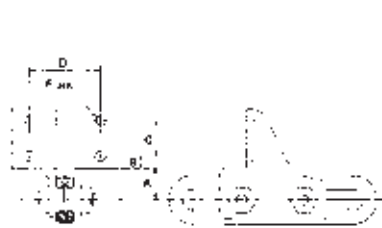

STYLE 2



STYLE 3

Type*	Chain Size	Style	Part No.	A	B	C	D	E	F Bolt Dia.	Weight Each	Material**
A	458	2	4F2C	13/16	1	1 hole	3 7/16		1/2	0.81	M.I.
A	468	2	4F2J	31/32	1	1 1/4	3 15/16		1/2	1.40	M.I.
A	468	2	4F2S	31/32	1	1 hole	3 15/16		1/2	0.93	M.I.
S	468	2	4F2D	15/16	1 5/8	1 hole	3 7/8		1/2	1.77	M.I.
A	678	1	6F2C	1 1/16	7/8	1 3/8	2 9/16	4 3/16	1/2	1.94	M.I.
A	678	3	6F2F	1 1/16	7/8	1 1/4	2 1/16	4 5/16	1/2	1.85	M.I.
A	698	2	6F2D	1 9/32	3/4	2	3 15/16		1/2	2.45	M.I.
A	998	2	9F2S	1 25/32	3/4	2	3 15/16		1/2	3.74	M.I.
A	998	2	9F2A	1 17/64	3/4	2	6		1/2	3.56	M.I.
A	998	3	9F2F	1 11/16	5/8	2 5/16	2 7/32	6 13/16	1/2	3.37	M.I.
A	998	2	9F2D	1 9/32	3/4	2	3 15/16		1/2	2.96	M.I.
A	9118	2	9F2C	1 5/8	5/8	2	4		1/2	3.90	M.I.
A	9148	1	9F2R	1 5/8	1 1/4	4	4 1/8	6 1/2	5/8	8.15	M.I.

*S - Side Link Attachment A - Bolted Centre Link Attachment **M.I. - Malleable Iron

FILLER BLOCKS

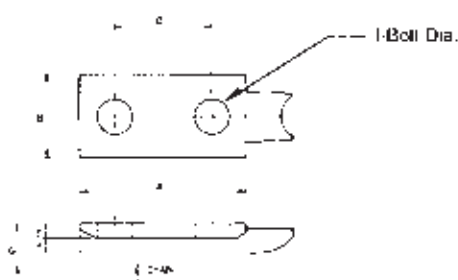

STYLE 2

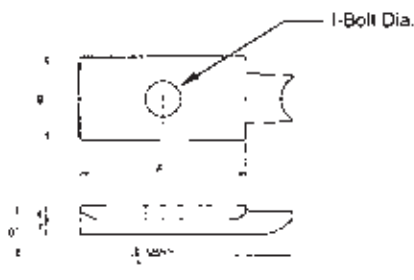

STYLE 3

Chain Size	Style	Part. No.	A	B	C	E	F	G	I Bolt Dia.	Weight Each
458	3	4-A-3-B	2 1/4	1 3/8		5/16	5/16	5/8	1/2	0.60
468	3	4-A-3-A	1 7/8	1 7/16		5/16	7/16	7/8	1/2	0.60
678	3	6-A-3-B	3 5/8	1 13/16		5/16	5/16	23/32	5/8	0.90
698	3	6-A-3	2 31/32	2 3/8		11/32	7/16	27/32	3/4	0.92
998	2	9-A-3	5 31/32	2 3/8	3 3/4	3/8	7/16	7/8	5/8	1.75
9118	2	9-A-3-B	5 3/8	3	3 5/32	3/8	9/16	1 1/16	3/4	2.15
9148	2	9-A-3-R	4 3/8	3 1/4	2 1/2	3/8	11/16	1 3/16	3/4	2.81

*M.I. - Malleable Iron C.S. - Cast Steel

142 SERIES CDM SYSTEMS CHAIN

ENGINEERING NOTES

To provide the proper chain strength for your application, the data below illustrates the ultimate strength of the chain along with its recommended nominal working load. CDM Systems uses a 5.5:1 safety ratio for proper application.

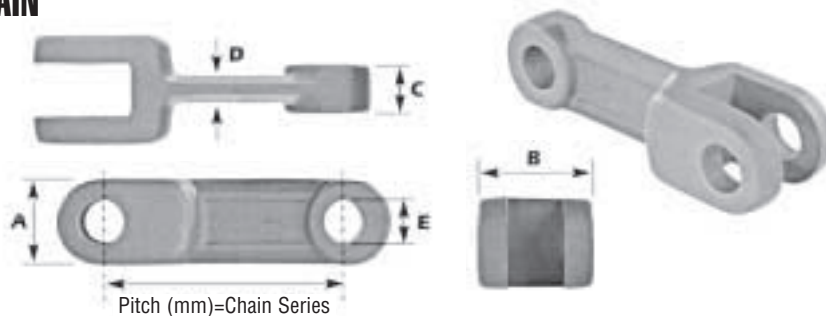

Chain Series	Ultimate Strength	Working Load	Weight	A	B	C	D	E	Recommended Sprocket Type
102 HVY	38,000 lbs.	6,900 lbs.	.99	1.375"	1.26	.55	.354	.709	Symmetrical ONLY
	17,275 kg	3,135 kg	.45	35mm	32	14	9	18	
142 STD	73,000	13,000	2.45	1.97"	1.65	.75	.47	.98	Symmetrical
	33,180	5,910	1.11	50	42	19	12	25	
142 HVY	99,000	18,000	3.74	1.97"	2.44	1.14	.63	.98	Symmetrical
	45,000	8,182	1.7	50	62	29	16	25	
142 STD/DBL	73,000	13,000	3.41	See table on page 37 for dimensional information					Non-symmetrical
	33,180	5,910	1.55						
142 HVY/DBL	99,000	18,000	4.72	See table on page 37 for dimensional information					Non-symmetrical
	45,000	8,182	2.15						
260 STD	150,000	27,270	14.0	2.95"	2.76	1.18	.79	1.26	Non-symmetrical
	68,180	12,390	6.4	75	70	30	20	32	

142 TRIPLE SERIES

APPLICATIONS

Typical applications for the triple (TPL) series chains include single-strand flight widths up to 30", and, when used in tandem with DBL series chains (for triple strand widths), flight widths reaching up to 12'-0" (3.7m).

TECHNICAL NOTES

The retaining mechanisms used to fasten flights onto the TPL link are standard 142 series U-pins or optional 5/16" grade 8 bolts, identical to those used with the DBL-series shown on page 37.

Also available for the TPL link are single-slotted flights that can be made in a variety of materials, shapes and sizes. These can easily be slipped into the groove of the chain link and fastened with a set of U-pins. Contact CAN-AM for more details.

Because of their unique design, 142 TPL links require the use of non-symmetrical sprockets ('TN' series) as illustrated on page 39.

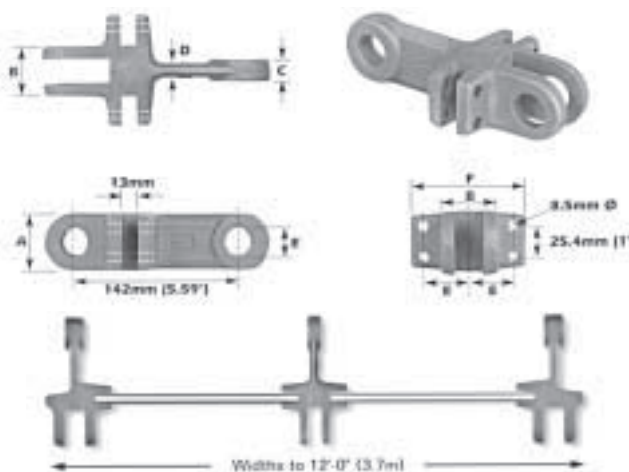

Chain Series	Ultimate Strength	Working Load	Weight	A	B	C	D	E	F
142 STD/TPL	73,000 lbs	13,000	4.07	1.97"	1.65	.75	.47	1.41	3.62
	33,180 kg	5,910	1.85	50mm	42	19	12	35	92
142 HVY/TPL	99,000	18,000	5.40	1.97"	2.44	1.14	.63	1.71	4.42
	45,000	8,180	2.45	50	62	29	16	43.5	112.3

This chain type requires the use of non-symmetrical sprocket plates.

142 DOUBLE SERIES CDM SYSTEMS CHAIN

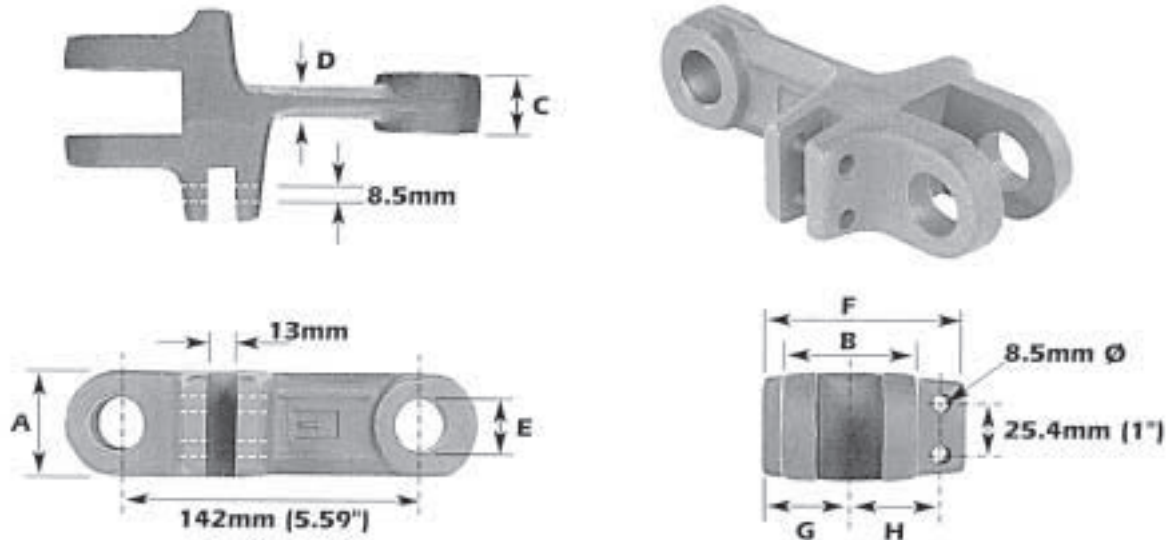

Chain Series	Ultimate Strength	Working Load	Weight	A	B	C	D	E	F	G	H
142 STD/DBL	73,000 lbs.	13,000	3.41	1.97"	1.65	.75	.47	.98	3.11	1.30	1.41
	33,180 kg	5,910	1.55	50mm	42	19	12	25	79	33	35
142 HVY/DBL	99,000	18,000	4.72	1.97	2.44	1.14	.63	.98	3.90	1.69	1.71
	45,000	8,182	2.15	50	62	29	16	25	99	43	43.5

This chain type requires the use of non-symmetrical sprocket plates.

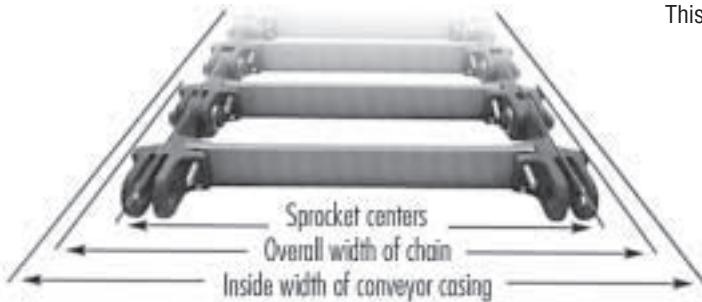

Chain Style	J	K	L	M
142 STD/DBL	2.60"	4.39	1.06	.53
	66mm	111	26.8	13.4
142 HVY/DBL	3.38"	5.95	.87	.43
	86	151	22	11

TO CALCULATE:

- Sprocket Centres: Subtract **J** from the overall chain width
- Flight Length: Subtract **K** from the overall chain width
- Hole Centres: Subtract **L** from the overall chain length

NOTE:

Use non-symmetrical sprockets. Flights over 2" high should be notched for sprocket clearance.

DOUBLE SERIES FLIGHTS

The DBL-series flight cutaway diagram shows the slots located at each end of the flight, which allow for expansion and contraction during operation.

One U-pin connector connects each end of this type of flight to a DBL-series chain link. In applications where the flight operates under unusually heavy loads or extreme widths, a stiffener is welded to the back of the flight for extra stability. Although the U-pin is the most common (and preferred) method of fastening DBL flights, 5/16" (8mm) grade-8 bolts can be substituted.

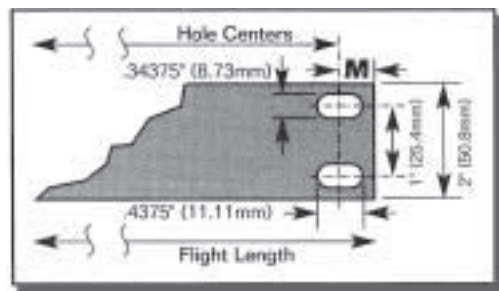

102 & 142 FLIGHTS CDM SYSTEMS CHAIN

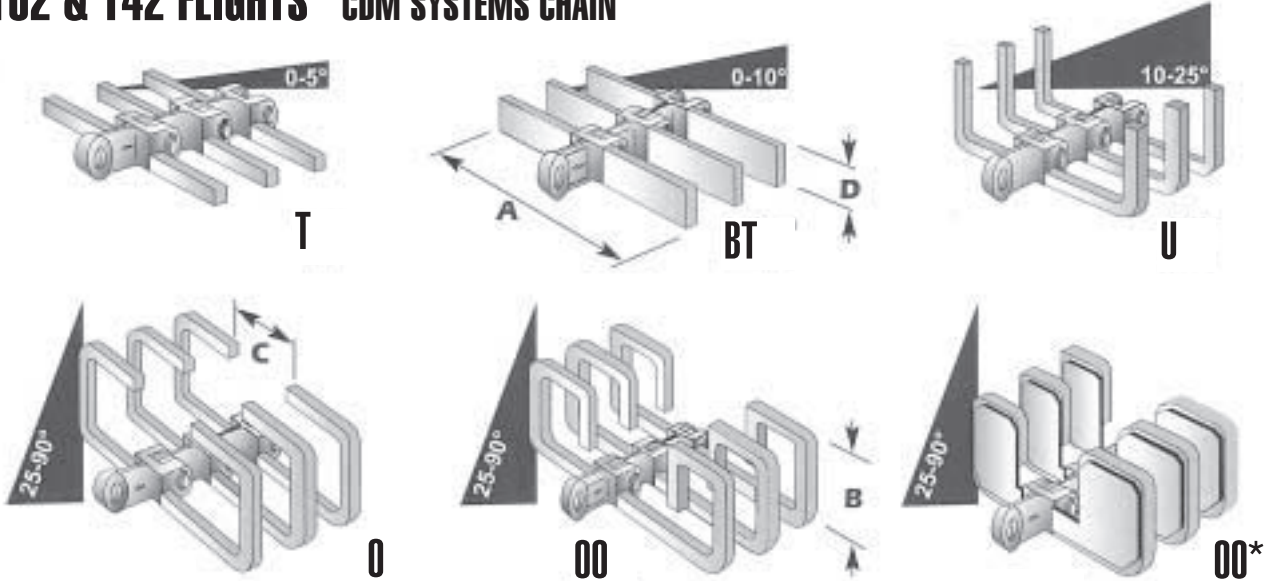

Chain Series	Conveyor Size	A	B	C	D	Weight (Flights only*)					
						T	BT	U	O	OO	OO*
102 Series	10"	9.88	4.50	3.00	1.375	-	2.2 lbs.	-	2.5	2.8	-
	254mm	250	114.3	76.2	35	-	1 kg	-	1.14	1.27	-
	12"	11.88	4.50	3.00	1.375	-	2.5	-	2.8	3.1	-
	305mm	300	114.3	76.2	35	-	1.14	-	1.27	1.41	-
	14"	13.88	4.50	3.00	1.375	-	2.8	-	3.3	3.6	-
	356mm	352	114.3	76.2	35	-	1.27	-	1.5	1.6	-
	16"	15.63	4.50	3.00	1.375	-	3.1	-	3.5	3.8	-
142 STD	406mm	397	114.3	76.2	35	-	1.41	-	1.6	1.7	-
	11"	10.94	5.88	4.75	2.00	1.41 lbs.	2.36	3.10	3.62	4.40	5.62
	280mm	278	149.5	120.7	50	.64 kg	1.07	1.41	1.65	2.0	2.55
	15"	14.88	7.56	5.50	2.00	2.04	3.41	4.30	5.45	6.80	9.38
	380mm	378	192	139.7	50	.93	1.55	1.95	2.48	3.09	4.26
	19"	18.81	10.0	6.25	2.00	2.72	4.45	5.65	7.16	9.27	14.07
	480mm	478	254	158.7	50	1.24	2.02	2.59	3.25	4.21	6.40
	25"	24.69	10.0	6.25	2.00	3.60	6.01	6.60	9.07	11.25	18.19
	635mm	627	254	158.7	50	1.64	2.73	3.0	4.12	5.11	8.27
	30"	29.81	10.0	6.25	2.00	4.43	7.39	7.44	10.66	12.90	21.67
	762mm	757.2	254	158	50	2.01	3.36	3.38	4.85	5.86	9.85

APPLICATIONS

The flights illustrated above represent the most frequently demanded designs in the industry and are by no means the only styles available. The T and BT style flights are used for horizontal through slight incline applications, normally between 0 to 10°, while the U flight can be used for horizontal/incline combinations through approximately 25°. The Modified BT, O, OO, and OO with filler plates are utilized in horizontal/inclined applications through 90° (vertical).

TECHNICAL DATA

The flight configurations represented above can handle the majority of your material handling requirements. The letter designator represents the style of the flight, while the number designates its frequency among links.

DESIGNATING FLIGHTS:

- BT-1 Flight every link
- BT-2 Flight every 2nd link, etc.



2500 SERIES BEARINGS

2500 SERIES CAN-AM BEARINGS

features include:

- Less down time: 3 piece design allows for quick repair of bearing while base remains in place. Simply jack up shaft 1/4", lift out cap and insert, and replace.
- Recessed grease fittings in castings to prevent damage.
- Excellent for log deck application and any larger slow-moving shafts, rollcases, etc.
- Can be mounted in any position
- Base is fab. or cast steel

- 4 choices of bushing material:
 - urethane
 - bronze
 - babbitt
 - zinc aluminum
- Steel base and ductile iron insert.

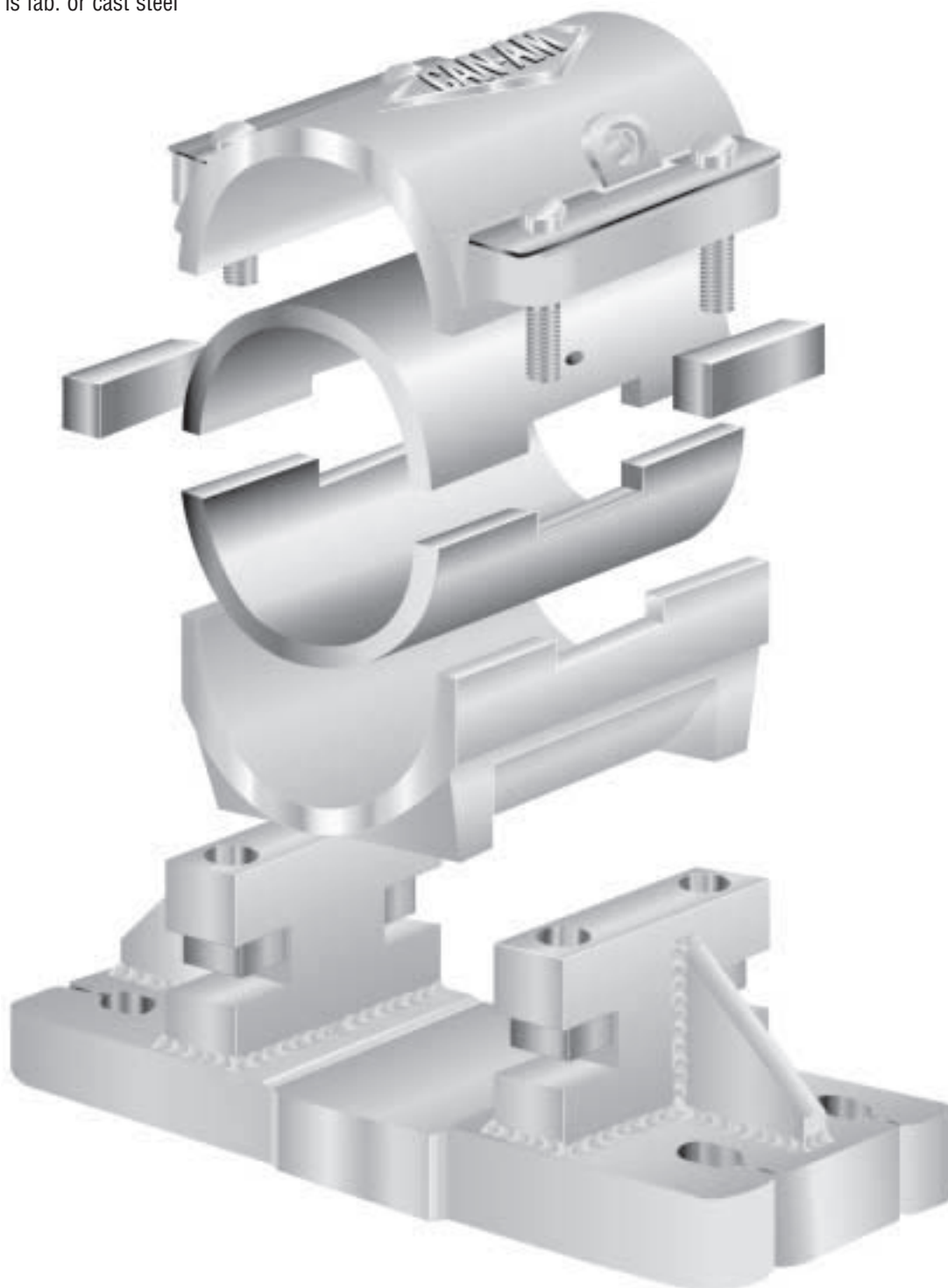

2500 SERIES BEARINGS

2500 SERIES CAN-AM BEARINGS

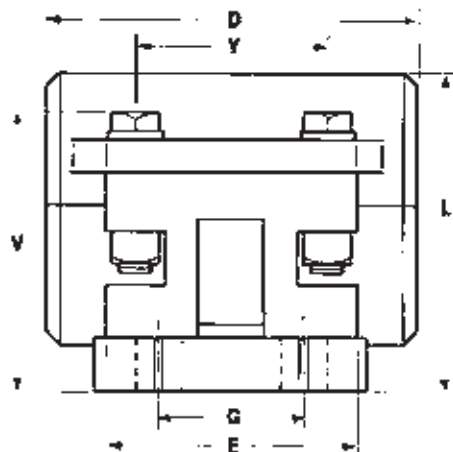
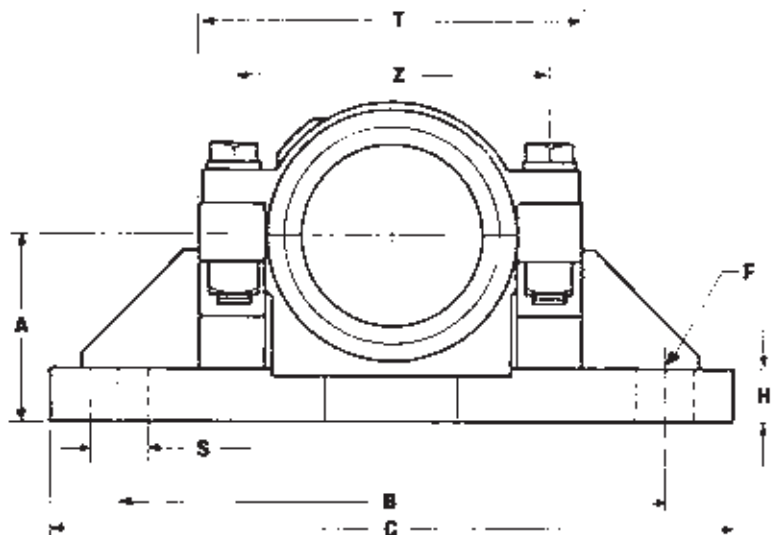

SUPPLY SERVICES LTD



Phone 0800 102 112 - www.supplyservices.co.nz

2-2500 SERIES (4 BOLT.)

	2 7/16	2 15/16	3 7/16	3 15/16	4 7/16	4 15/16	5 7/16	5 15/16	6 7/16	6 15/16	7 7/16 7 15/16 8
A	2 3/4	3 1/4	3 1/2	3 3/4	4 1/8	4 1/2	5 1/2	5 1/2	6 1/2	6 1/2	7
B	8	8 3/4	10 1/2	12	13 1/2	15	16 1/2	16 1/2	19	19	21 1/2
C	10 1/4	11	13	14 3/4	16 1/2	18	20 1/2	20 1/2	23	23	26
D	5	6	7	8	9	10	12	12	14	14	16
E	3 3/4	4 1/4	4 3/4	5 1/4	6 1/4	7	8 1/2	8 1/2	10	10	11
F	5/8	5/8	3/4	3/4	7/8	7/8	1 1/8	1 1/8	1 1/4	1 1/4	1 1/4
G	2	2 1/2	2 3/4	3	3 1/2	4	5	5	6	6	6 3/4
H	1	1	1	1 1/4	1 1/4	1 1/4	1 1/2	1 1/2	2	2	1 3/4
L	5	5 5/8	6 3/8	6 7/8	7 5/8	8 1/2	10	10	11 1/2	11 1/2	13
S	1	1	1 1/4	1 3/8	1 1/2	1 5/8	1 7/8	1 7/8	2	2	2 1/4
T	5 5/8	6	7 1/4	7 5/8	8 7/8	9 1/2	12	12	14 1/8	14 1/8	17
V	4 3/8	5	5 1/4	5 5/8	6	6 1/2	7 5/8	7 5/8	8 3/4	8 3/4	9 3/4
Y	2 3/4	3 3/16	3 5/8	4	4 7/8	5 1/2	6 3/4	6 3/4	7 5/8	7 5/8	8 1/2
Z	4 3/4	5	6	6 1/2	7 1/2	8	10 1/8	10 1/8	12	12	14 3/8
WT	25	35	46	64	90	115	200	200	300	300	480

2500 SERIES (2 BOLT.)

	2 7/16	2 15/16
A	2 3/4	3 1/4
B	8	9 1/2
C	10 1/4	12 1/4
D	5	6
E	3 3/4	4 1/4
F	3/4	7/8
G	-	-
H	1	1
L	5	5 5/8
S	1 1/8	1 3/8
T	5 5/8	6
V	4 3/8	5
Y	2 3/4	3 3/16
Z	4 3/4	5
WT	25	35

1000 SERIES BEARINGS

1000 SERIES CAN-AM BEARINGS

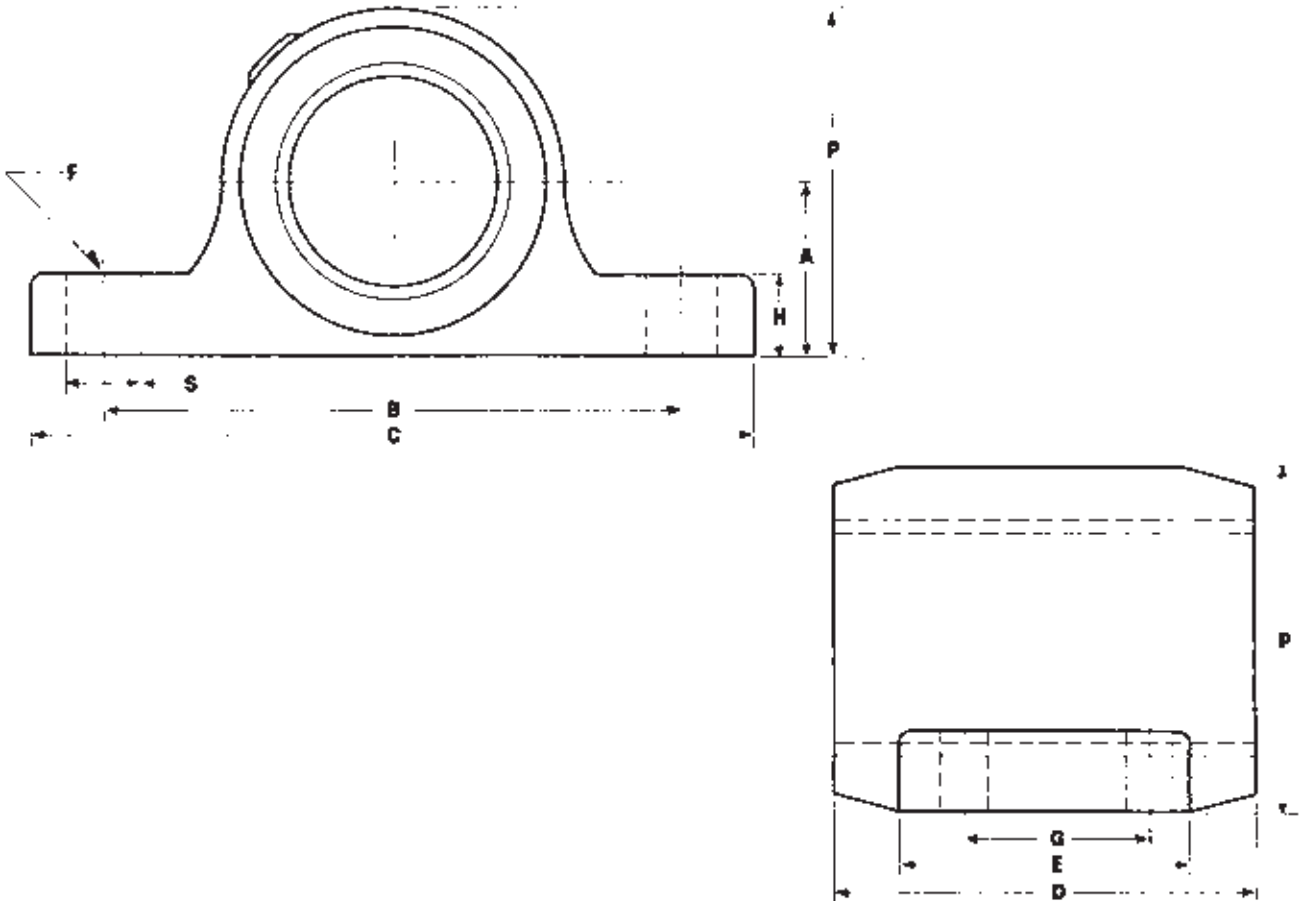

2-1000 SERIES — 4 BOLT BASE

	2 7/16	2 15/16	3 7/16	3 15/16	4 7/16	4 15/16
A	2 1/4	2 1/2	3	3 1/4	4 1/8	4 1/2
B	7	8 3/4	10	11	13 1/2	15
C	9 1/4	11 1/4	12 1/2	13 3/4	16 1/2	18
D	5	6	7	8	9	10
E	4	4 1/2	5	5 1/2	6 1/4	7
F	5/8	5/8	3/4	3/4	7/8	7/8
G	2	2 1/2	2 3/4	3	3 1/2	4
H	1 1/8	1 1/4	1 3/8	1 1/2	1 3/4	1 7/8
P	4 3/8	4 7/8	6	6 1/2	7 7/8	8 1/2
S	1 1/8	1 1/8	1 1/4	1 3/8	1 1/2	1 5/8
WT. lbs.	14	24	36	51	75	100

1000 SERIES — 2 HOLE BASE

1 15/16	2 3/16	2 7/16	2 15/16
1 3/4	2	2 1/4	2 1/2
6	6 1/2	7	8 1/2
8	8 1/2	9 1/4	11 1/4
4	4 1/2	5	6
2 3/4	3	3 1/4	4
5/8	5/8	3/4	7/8
-	-	-	-
7/8	1	1 1/8	1 1/4
3 1/2	3 7/8	4 3/8	4 7/8
1	1	1 1/8	1 3/8
8	11	14	24

Available in Babbitt, Urethane, Zinc-Aluminum & Bronze bushed. Grease fittings are 45° and countersunk into casting to prevent damage. All bearings have ductile housings, and have machine mounting surfaces.

SUPPLY SERVICES LTD 
 Phone 0800 102 112 - www.supplyservices.co.nz

BEARING LOAD RATING

BEARING LOAD RATING TABLES

The following load rating tables apply when the following installations and operating conditions are met:

1. Maintain adequate grease lubrication. Use of EP grease is recommended.
2. Align bearings with shaft for uniform load distribution.
3. Normal running loads should not exceed ratings shown in load tables.
Starting & occasional peak loads should not exceed ratings by more than 100%.
4. The journal shaft surface should be equal to that of commercial steel shafting (about 32 micro-inches) and the diameter within the tolerances of commercial steel shafting.
5. Ambient temperature should not exceed 130° F. for babbitt, 300° F for bronze, 250°F for ZA and 225° F for urethane bushed bearings. If the shaft transmits heat from a source such as an oven, the shaft temperature at the bearing should not exceed these temperatures.
6. Where thrust loads are present, install a bronze washer and fasten it in place with a set collar against end of bearing.
The bearing ends are finished.

RADIAL LOAD RATINGS FOR RIGID BRONZE OR ZA12* SLEEVE BEARINGS

Shaft Size Inches	Shaft Speed, RPM (load rating in lbs.)								
	10	50	100	150	200	250	300	350	400
1 15/16 - 2	1920	1880	1830	1790	1740	1690	1640	1590	1500
2 3/16 - 2 1/4	2440	2390	2320	2240	2170	2100	2030	1960	1390
2 7/16 - 2 1/2	3020	2940	2850	2750	2650	2560	2460	1860	1090
2 11/16 - 2 3/4	3660	3560	3430	3300	3170	3040	2620	1580	545
2 15/16 - 3	4370	4230	4060	3890	3720	3550	2440		
3 7/16 - 3 1/2	5960	5740	5470	5200	4930	3610	1440		
3 15/16 - 4	7790	7460	7060	6650	5910				
4 7/16 - 4 1/2	9860	9400	8820	8240	5400				
4 15/16 - 5	12180	11540	10740	9950	4090				
5 7/16 - 5 1/2	14740	13880	12820	10348	1820				
5 15/16 - 6	17530	16420	15040	9520					
6 7/16 - 6 1/2	20560	19150	17390	7900					
6 15/16 - 7	23840	22070	19870	5350					
7 7/16 - 7 1/2	29170	26850	23950	1880					
7 15/16 - 8	31090	28450	23410						

Load ratings are based on industry standards by the Mechanical Power Transmission Association

* Zinc Aluminum alloy (ZA12) has the same wear property as 660 Bronze

SUPPLY SERVICES LTD 
Phone 0800 102 112 - www.supplyservices.co.nz

RADIAL LOAD RATINGS FOR RIGID BABBITT SLEEVE BEARINGS

Shaft Size Inches	Shaft Speed, RPM (load rating in lbs.)								
	10	50	100	150	200	250	300	350	400
1 15/16 - 2	1150	1110	1060	1010	965	915	865	815	730
2 3/16 - 2 1/4	1460	1400	1330	1260	1190	1120	1050	975	410
2 7/16 - 2 1/2	1800	1730	1630	1530	1430	1340	1240	645	
2 11/16 - 2 3/4	2190	2080	1950	1820	1690	1560	1150	110	
2 15/16 - 3	2600	2470	2300	2130	1960	1790	675		
3 7/16 - 3 1/2	3550	3330	3060	2790	2520	1200			
3 15/16 - 4	4640	4310	3910	3500	2760				
4 7/16 - 4 1/2	5870	5410	4830	4250	1410				
4 15/16 - 5	7240	6600	5810	5010					
5 7/16 - 5 1/2	8750	7900	6840	4360					
5 15/16 - 6	10410	9300	7910	2390					
6 7/16 - 6 1/2	12200	10790	9020						
6 15/16 - 7	14120	12360	10150						
7 7/16 - 7 1/2	17270	14950	12050						
7 15/16 - 8	18390	15750	10710						

Load ratings are based on industry standards by the Mechanical Power Transmission Association

RADIAL LOAD RATINGS FOR RIGID URETHANE SLEEVE BEARINGS

Shaft Size Inches	Shaft Speed, RPM (load rating in lbs.)								
	10	50	100	150	200	250	300	350	400
1 15/16 - 2	920	890	850	810	770	730	690	650	580
2 3/16 - 2 1/4	1170	1120	1060	1010	950	900	840	780	330
2 7/16 - 2 1/2	1440	1380	1300	1220	1140	1070	990	520	
2 11/16 - 2 3/4	1750	1660	1520	1460	1350	1250	920	90	
2 15/16 - 3	2080	1980	1840	1700	1570	1430	540		
3 7/16 - 3 1/2	2840	2660	2450	2230	2020	960			
3 15/16 - 4	3710	3450	3130	2800	2210				
4 7/16 - 4 1/2	4700	4330	3860	3400	1130				
4 15/16 - 5	5790	5280	4650	4010					
5 7/16 - 5 1/2	7000	6320	5470	3490					
5 15/16 - 6	8330	7440	6330	1910					
6 7/16 - 6 1/2	9670	8630	7220						
6 15/16 - 7	11300	9890	8120						
7 7/16 - 7 1/2	13820	11960	9640						
7 15/16 - 8	14710	12600	8570						

Load ratings are based on industry standards by the Mechanical Power Transmission Association

TECHNICAL SECTION

AVAILABLE OPTIONS TO CAN-AM CHAINS

Most CAN-AM products can be ordered with mechanical properties to suit specific or unique applications. Some of the variables are listed below.

1. Non heat treated sidebars or barrels.
2. Through heat treated sidebars, barrels or rivets.
3. Induction hardening of already through hardened sidebars, barrels and rivets
4. Carborized barrels
5. Normalized sidebars and barrels to improve notch toughness for cold weather applications
6. Zinc plated, hard chrome plated, stainless and other rivets in optional steels e.g. 1541, 8620, 4140, 4340
7. Shot peened rivets
8. Prelubricated chain, (molyslip or other)
9. Construction by means of standard riveting, welded rivets, or pins

Note: All standard mill class chains are supplied with heat treated rivets.

WELDING PROCEDURE FOR CAN-AM STEEL CHAIN

Preheat chain and attachments to 200° – 350° F before welding. Preheat temperature is affected by many variables, some are thickness of material, geometry of attachment, and chemical composition of the steel.

1. Use a dry 7018 electrode, or #116 flux core, or wire feed with argon/CO₂ shield.
2. Always observe proper welding techniques.

Note: CAN-AM Chains is not responsible for chain, or attachment failure, or welding defects, when ex-factory welding is the cause of the failure or defect, and that welding has been performed by other than our own factory certified welders.

LUBRICATION

Normal chain wear is often the result of friction between the rivet and I.D. of the barrel. Sprocket size and pitch angle will determine the relative motion between parts, and the degree of wear.

Lubrication of these surfaces would lessen wear and slow the progress of corrosion.

Since lubrication significantly reduces the amount of wear to a chain, it would seem to be good economics to pre-lube chain at the point of manufacture and to lubricate that chain throughout its service life. Even a fine spray of water adds to service life.

BREAK-IN PERIOD

Following a proper and logical “break-in” routine will enhance the service life of welded steel chain products.

CAN-AM RECOMMENDS:

1. Chain should be run empty for a period of 6–8 hours, or whatever is practical. A fine spray of water or other lubricant would promote surfaces to polish up.
2. Make sure sprockets are correctly aligned and that wear strip is in good condition.
3. New chain should always be run on new sprockets. Even if the sprockets are only slightly out of pitch, or have even the smallest “hook” to the teeth, those sprockets will dramatically reduce chain life.
4. Check to ensure that chain will not “bind” or “hang up” along the conveyor path.

SIDLIFT LOG HAUL CONVEYORS

The following recommendations will help in the maintenance of existing conveyors and the design and installation of new systems.

1. **Chair Height** – This dimension is controlled by the angle of incline in degrees of the conveyor. The most satisfactory incline is 30 degrees. Using that figure the chair height should be 1/3 the diameter of the largest log expected. In other words a 36" diameter log must have a 12" high chair minimum.
2. **Head End Design** – The sprocket centre must be far enough back from the end of the log haul conveyor to allow for a skid between the top of the sprocket and the end of the log haul conveyor trough. If this were not designed in this manner, the chair could bump it as it travels around on its way back down the sidelift conveyor.
3. **Chain Return** – A catenary return is best for the chain, chairs and conveyor structure, and the slack of the chain should be 5-10% of the sprocket centers.

CAN-AM SIDELIFT LOG CHAIRS

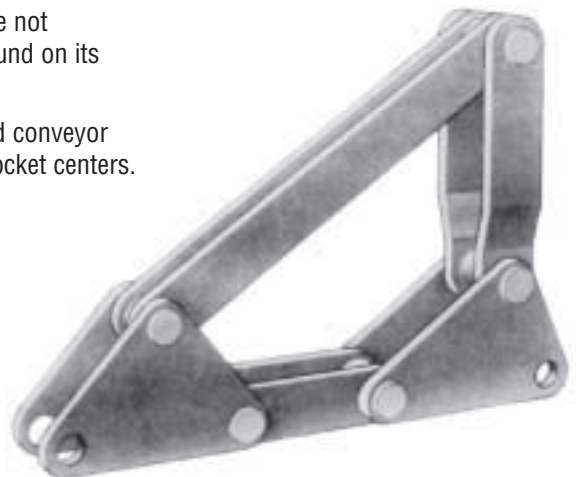

SUPPLY SERVICES LTD 
Phone 0800 102 112 - www.supplyservices.co.nz

CONVEYOR INSTALLATION AND MAINTENANCE FOR THE FOREST PRODUCTS INDUSTRY

CAN-AM welded steel chains are manufactured of high quality steels, not available “off the shelf” from any steel supplier. These steels, in combination with careful design and expert manufacturing, have produced a high quality chain product that will give superior life and performance when properly maintained.

The recommendations in this catalog are based on our own experience and observations after almost 40 years of manufacturing chain for the forest products and other industries. The thoughts and suggestions of millrights, maintenance people, engineers, and others have contributed to our philosophy of the maintenance of chain in an industrial environment.

INSTALLATION OF NEW CHAIN IN A NEW CONVEYOR

Check the following:

1. The width of the trough need not be more than 1/2" wider, on each side, than the overall width of the chain including attachments. Chains should not wander from side to side.
2. The wear strip must be full width of the conveyor so that the chain runs on the sidebar, the barrel of the chain does not support the chain itself.
3. Chains that are run in a trough should be at the correct height. Half the height of the sidebar is a good rule of thumb. If the chain is too low, the log or boards will be slowed in their movement. Conversely, a chain running too high in the trough can be easily forced out of the trough by side loads.
4. The root line of the sprocket or drum should be approximately 1/2" above the level of the conveyor wear strip. This allows the chain to be lifted slightly as it contacts the sprocket. The benefits are: immediate contact with the sprocket tooth, rather than 1/3 the way around the drum, and, improved wear life. A low root line relationship between the sprocket and wear strip causes the chain to be pulled down across the end of the wearstrip. This causes premature wear on the sidebars.
5. Be certain the chain has the correct amount of slack on the return. A good rule of thumb for conveyor chain is 5-10% of the sprocket centers depending on the size and weight of the chain.
6. Pay as much attention to the chain return as to the load side. Use a trough if possible. If not, again, the correct amount of slack is important. Too much slack can cause the chain to sway or jump—a condition that increases chain wear.
7. The last step is never to be forgotten for successful operation. Breaking in a new chain is a very important procedure. The chain should be run, no load, for a few hours (6–8). This will smooth up the chain running surfaces as well as the wear strip and the sprocket tooth face and allow rivet OD and barrel ID to polish up. This will ensure maximum life. It is advisable to have a film of clean water on the chain during the break-in period, and for that matter all the time. Water is an excellent lubricant because it will carry away the dirt generated by the chain rubbing the wear strip and sprocket. A fine spray on the chain at the tail end is enough. It is not necessary to have so much water that it makes a mess under the conveyor.

SUPPLY SERVICES LTD 
Phone 0800 102 112 - www.supplyservices.co.nz

CUT DOWN ON MAINTENANCE COSTS

1. The overall width of the attachment, including the link, should not exceed twice the length of the chain pitch. For example, WR 132 is 6.050 pitch x 2 = 12.1" so, a 13" cradle would be suitable. Anything longer might cause the chain to twist under leverage, and break the link.
2. Head and tail sprockets, when used with attachment chain, should be flanged to locate the attachment when it enters and travels around the sprocket. Flanges are meant only to locate the attachment, not support it. If contact is made, fatigue failures may occur on the attachment welds. Remember to mount the sprocket or idler so that the root line is slightly higher than the wear strip.
3. Flare the trough and return ends slightly to prevent the attachments from hanging up on a squared edge.
4. Wear strips must be full width of the conveyor to support the attachments.
5. The preferred wear strip is a minimum of 450 BHN plate or one of several hardened UHMW products. UHMW, of course, has a very low coefficient of friction, and is best suited for **non-abrasive** locations.
6. Sprocket pitch diameters should be about 4 X's the chain pitch, for mill chains and 3 X's the pitch for drag chains. Also, it's better to use sprockets with an odd number of teeth.
7. Sprocket wear – A hooked sprocket tooth will eventually hold onto the chain beyond it's normal release point. The worst scenario would have the chain "wrap" the sprocket and break or tear up the drive. Install new chain and sprockets when the chain starts to climb the sprocket tooth, the pitch has now elongated due to wear between the rivet and barrel and possibly elongation of the sidebar hole. This chain will continue to wear itself and the sprocket even more rapidly from this point onward.

Keep the area around tail idlers clear and the idlers themselves turning. Use sprockets if necessary to avoid excess wear on the barrels being dragged around the idler face, if the idler isn't functioning, for the small difference in cost, it's always advisable to install sprockets at the tail end of the conveyor.

Keep idlers and drive sprockets aligned.

CONVEYOR CHAIN SELECTION

1. Minimize the number of different sizes of chain in use throughout the mill. Quite often the same chain used on a log deck will also be suitable in a waste conveyor by adding on some weld-on cross flights.
2. Conveyor speeds have increased over the years and the chart below, showing recommended maximum FPM, may be of assistance when selecting conveyor chain. Don't forget that **Induction Hardened** pins & barrels can **further increase** these maximums. Consult with your CAN-AM factory representative.

Note the effect that a larger diameter sprocket has on the maximum FPM allowable.

If larger sprockets are not practical then often the best answer is to go to a smaller pitch chain. The shorter pitch length will be able to run faster over a given diameter sprocket as its pin & barrel articulation will be less than the larger pitch chain.

Also, when reviewing the above, consider using the smaller chain in its **XHD** version to increase the maximum working load.

3. Chain wear can be affected by many factors. We have listed some below with our suggestions:

Side Bar Wear

- Check the wear strip for galling. Use a hard wear plate, minimum 400 BHN.
- Grit & dirt can cause excessive wear and if it cannot be eliminated then Induction Hardened components will help increase the service life.
- UHMW or nylon wear strips can help reduce wear, friction and horsepower and are best used in a non-abrasive environment.

Pin to Barrel Wear

- Excessive speed and/or load are two common factors. Induction hardened components will help increase the service life.

CAN-AM can also supply chains with special components to tackle these problems, regreasable pins and specially hardened components are tools we have suggested and used with great success.

MAXIMUM FPM ALLOWABLE

Number of Teeth Sprocket	Pitch in Inches						
	2	4	6	9	12	18	24
6	254	180	147	120	104	85	68
7	297	210	171	140	121	99	80
8	340	240	196	160	138	113	91
9	382	270	220	180	155	127	103
10	425	300	245	200	173	141	115
11	466	330	270	220	190	156	125
12	509	360	294	240	207	170	
13	551	390	318	260	224	184	
14	594	420	343	280	242	198	
15	636	450	367	300	259	212	
16	677	480	392				
17	717	510	416				
18	761	540	440				
19	803	570	465				
20	844	600					
21	886	630					

HEAD END DRIVE FOR CHAIN CONVEYORS

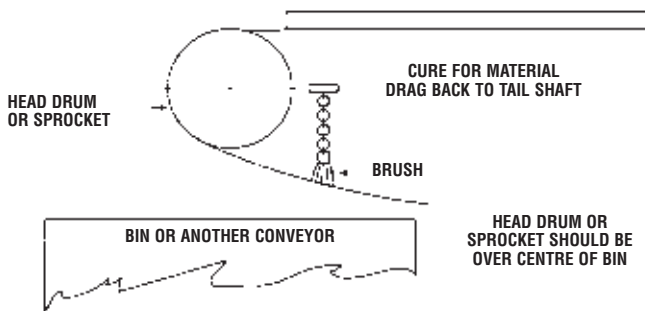

"WATERFALL" DRIVE FOR CHAIN CONVEYORS

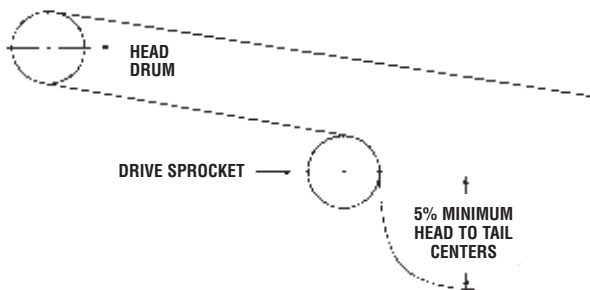

TYPICAL MILL CHAIN DRIVE ARRANGEMENTS

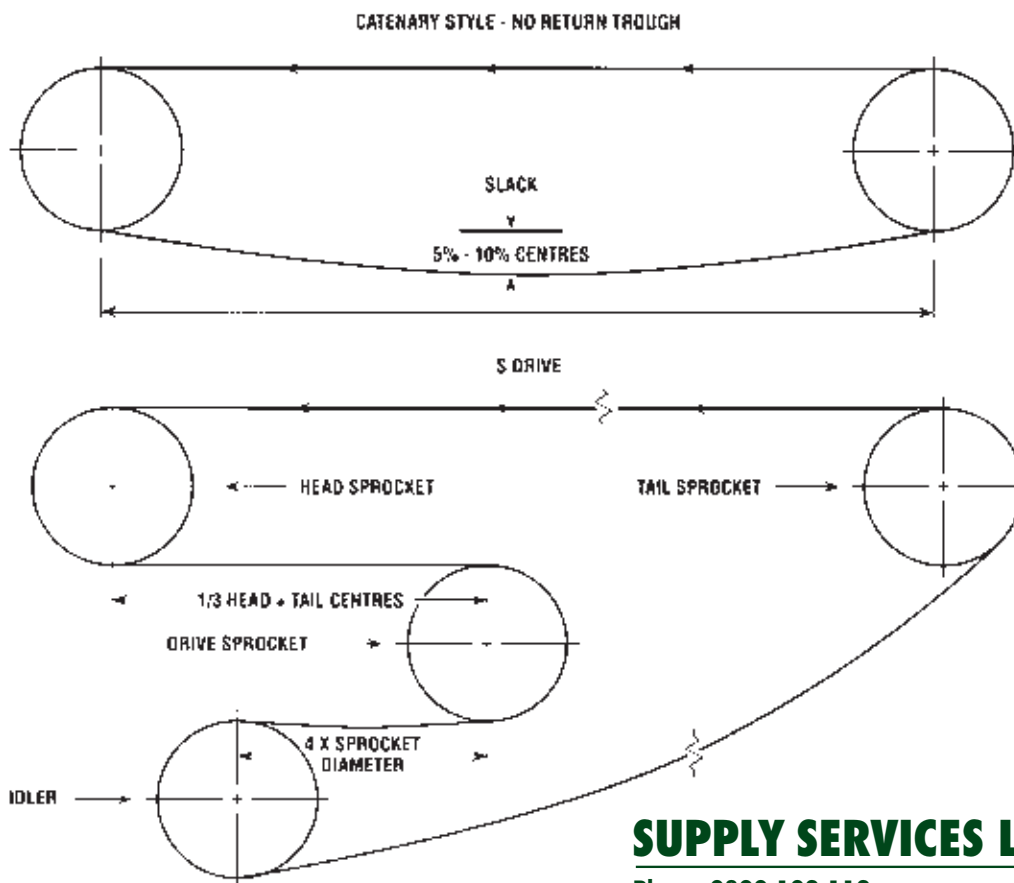

SUPPLY SERVICES LTD

Phone 0800 102 112 - www.supplyservices.co.nz

MILL CHAIN FIT IN TROUGH

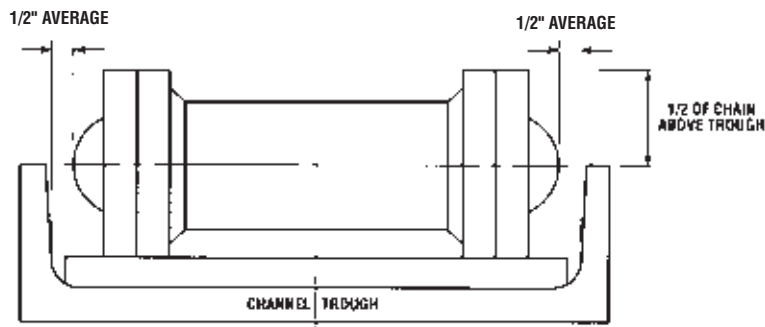

SPROCKET TO TROUGH ALIGNMENT

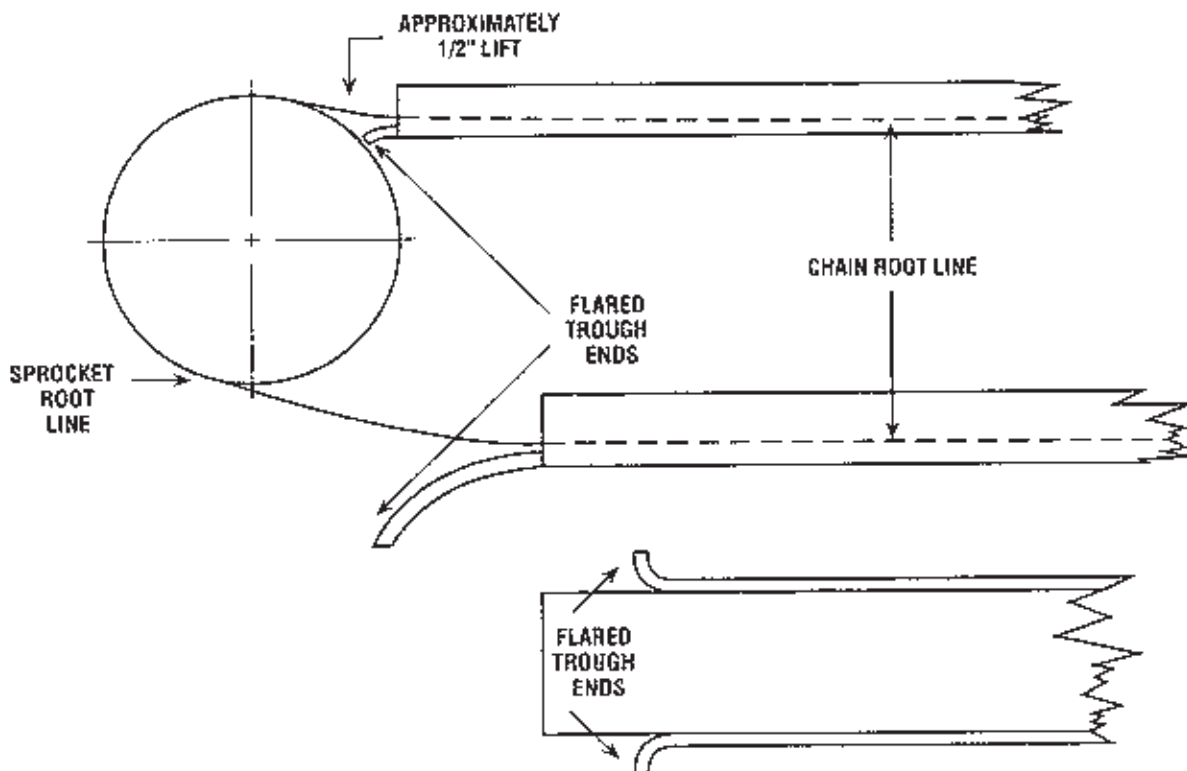

LONG LINK CHAIN CONVEYORS

Sprocket – The sprocket should be 7 tooth for longer chain life. Also the sprocket should be drum flanged to a width equal to the length of the conveyor flights, to prevent the flights from flopping around as they travel around the sprocket. It will also help in keeping them level so they will lead into the return conveyor trough smoother.

Lubrication – A spray of clean water can be applied directly to the chain as it contacts the top tooth of the sprocket. This will lubricate the chain at the heaviest load point.

Head Drum – The head drum should be a diameter that is 5 times the chain pitch in inches. For example, the head drum dimension for 6" chain would be 30" in diameter. The head drum is the load drum of the conveyor. That is why we stress the importance of the large diameter.

Tail and Idler Drum – The tail drum should be 4 times the chain pitch in diameter, or 24" for 6" pitch chain. This drum has a tendency to plug up from trash collection dragged back on the return. That is why it is important to have a brush installed behind the head drum touching the chain and flights keeping the sawdust, etc. from being moved through the system.

The idler drum should be a swinging idler to provide constant tension to the chain. (See drawing). A good insurance policy is a pair of limit switches wired to the conveyor power source, one on each side of the swing structure, to stop the conveyor should it become too tight or too loose during operation. IT IS 100% NECESSARY THAT ALL DRUMS TURN FREELY!

Flights – Selection of the flights for long link conveyors is every bit as important as any other part of the system. They must fit the chain correctly, otherwise adverse wear on the chain and the flights can occur. CAN-AM offers different types of flights, as shown on pages 31 and 32 of the CAN-AM catalog. The oldest and probably the most widely used is the "Skookum" flight. It is fabricated mild steel and available as a bolt together or weld together part. Other flights are our "Tang" style which is a cast steel slip together and weld flight with large surfaces top and bottom where they slide on the conveyor bottom, UHMW flights are also available, see page 33.

LONG LINK CHAIN DRIVE

SUPPLY SERVICES LTD



Phone 0800 102 112 - www.supplyservices.co.nz

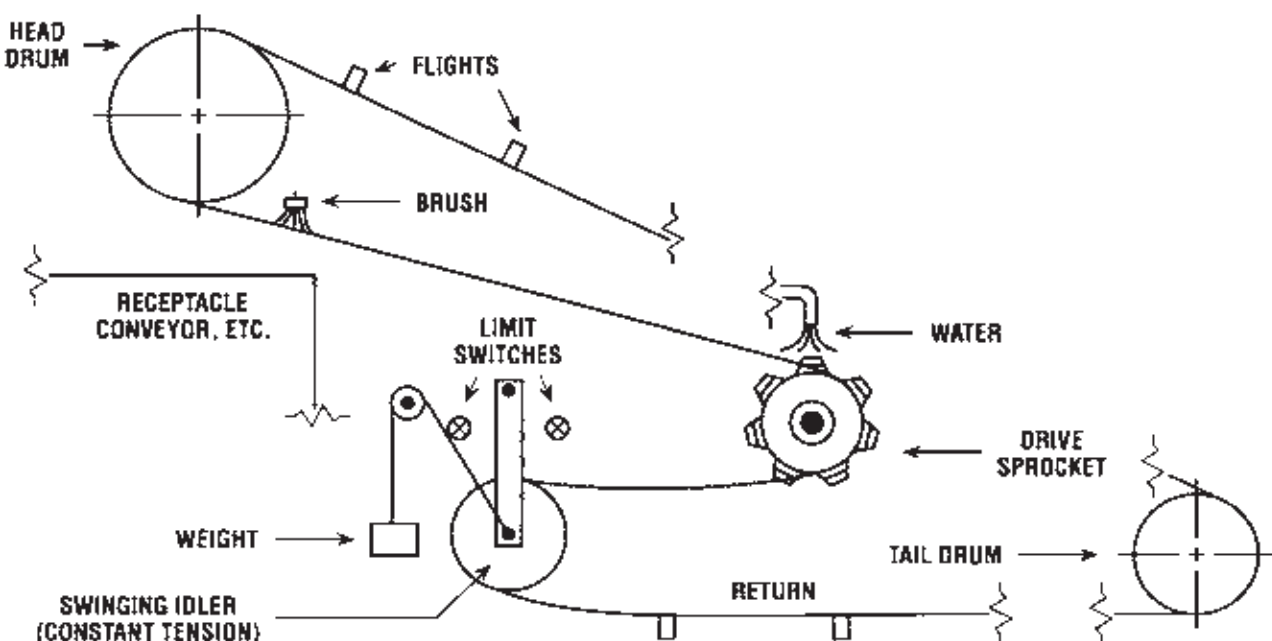

TERMS AND CONDITIONS

General

These conditions supersede those contained in all previous quotations, orders and agreements whether written or oral and shall be the only conditions governing future transactions between the seller and the buyer, unless otherwise specifically agreed to in writing by the seller. Clerical errors are subject to correction. Time is of the essence hereof.

Quotation Period

A quotation is valid for a period of Thirty (30) days from quotation date. It is subject to partial acceptance only upon written consent of the seller.

Delays

Delivery dates are estimates only and are predicated on conditions as known to the Seller at the time of the quotation and the Seller shall not be liable for any direct, indirect or consequential damages due to delays or inability to perform caused by factors beyond its control including but not limited to acts of God, flood, war, riot, fire, accident, explosion, labour trouble, acts of Government, delay or default by sub-contractors or suppliers of material or services or transportation difficulties. Delivery dates shall be extended by the period of such delay.

Terms

All orders are subject to approval of Seller's Credit Department. All payments past due shall bear interest at the rate of 1-1/2% per month (equivalent to 18% per annum) until paid. Orders cannot be cancelled or changed or deliveries deferred, except on terms satisfactory to the Seller. If the Buyer fails to pay an installment of the purchase price when due, the Seller may stop work and, at the Seller's option, the entire purchase price shall become immediately due and payable.

Payment

All prices quoted are F.O.B. Seller's plant. Sale shall be deemed complete and the property in the goods pass when the goods are ready for delivery. Goods shall be invoiced when ready for delivery and payment thereof shall be net cash Thirty (30) days from the date of invoice. The Seller reserves the right to alter the terms of payment or to require payment prior to the time of delivery if, in the Seller's opinion, the Buyer's financial condition or other circumstances do not warrant delivery on the terms originally agreed upon.

Taxes

Prices quoted are exclusive of all sales and excise taxes, customs duties or other taxes or levies, and the Buyer is to be responsible therefor.

Shipment

If transportation is quoted, the Seller shall decide carrier and method of shipment unless Buyer's instructions have been agreed to by the Seller prior to quotation. The Seller will not be responsible for any loss or damage to the goods after they are ready for delivery to carrier and the Buyer agrees to assume such risks, insurance premiums, special crating or shipping charges shall be arranged and paid for by the Buyer.

Escalation

Prices quoted are based on correct labour rates and material costs and, if applicable, current freight rates, customs duties, taxes and foreign exchange rates and are therefore subject to change to the extent of any change (either before or after acceptance of this quotation and during the contract period) in any of the foregoing items.

Inspection

If Buyer reserves the right to inspect the goods prior to delivery such inspection shall be made within Seven (7) days of Buyer receiving written notice from Seller that the goods are ready for delivery; otherwise Buyer shall be deemed to have waived all rights of inspection and delivery to the Buyer shall be deemed to be complete at the end of the Seven (7) day period.

Storage and Return of Goods

If the Buyer is unable to remove the goods within Thirty (30) days of their delivery ex Seller's plant, the Seller shall be entitled to charge storage on the goods. Goods cannot be returned except upon Seller's written consent, and will be subject to a restocking charge equal to 25% of the Buyer's invoice.

Patents

The Buyer agrees to save the Seller harmless from all patent infringement claims, liability and expense resulting from the Seller's compliance with the Buyer's specifications or designs now or hereafter forming a part of any work or from written instructions of the Buyer directing the manner in which the Seller shall perform any work.

Applicable Law

Any contract between the Buyer and Seller shall be subject to and construed in accordance with the laws of the state or province wherein the goods were supplied from.

Specifications

In accordance with the policy of the Seller to constantly improve its products, the specifications, designs, and dimensions contained in this catalog are subject to change without notice.

Responsibility

The Seller declines responsibility for any damages incurred as a result of improper installation of attachments installed by firms other than the Seller.

Packaging

Chain is shipped in wired bundles of approximately 10 foot lengths. Any other lengths required shall be made on Buyer's authorization at time of order.

Dimensions and Weights

Tabular dimensions and weights are approximate and non-binding. Design improvements may result in variations to published figures. Verification is recommended.

SUPPLY SERVICES LTD 
Phone 0800 102 112 - www.supplyservices.co.nz

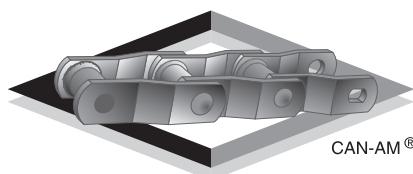
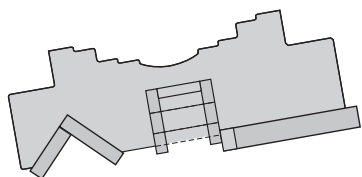
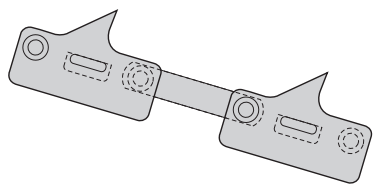

CAN-AM®

PRODUCTS AND SERVICES PROVIDED BY CAN-AM CHAINS

SHARP CHAINS D.L.I. CHAINS AUTO ROTATE CHAINS

CAN-AM Chains make a full range of specialty chain and flights to suit all facets of industry. Pictured here are two examples of high speed scanner/canter feed chains for the lumber industry.

CAN-AM FABRICATED STEEL SPROCKETS

Normally made of mild steel plate. Heat treated and induction hardened plate sprockets with hardnesses from 360 to 500 BHN are available.

CAN-AM ROLLER CHAIN

Built to our exacting standards and requirements to exceed ANSI standards. These chains are all made with solid rollers and bushings.

SPLIT SLEEVE BEARINGS 2-2500 SERIES

CAN-AM manufactures a full line of these bearings and stocks them with liners of polyurethane, bronze, babbitt or Zinc Aluminum.

Please contact us for further information or visit our web site at www.can-amchains.com

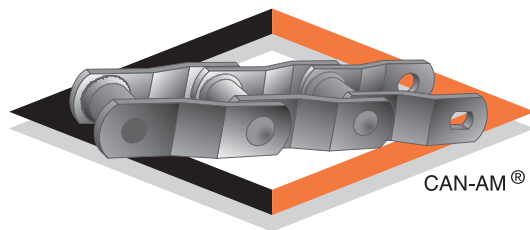
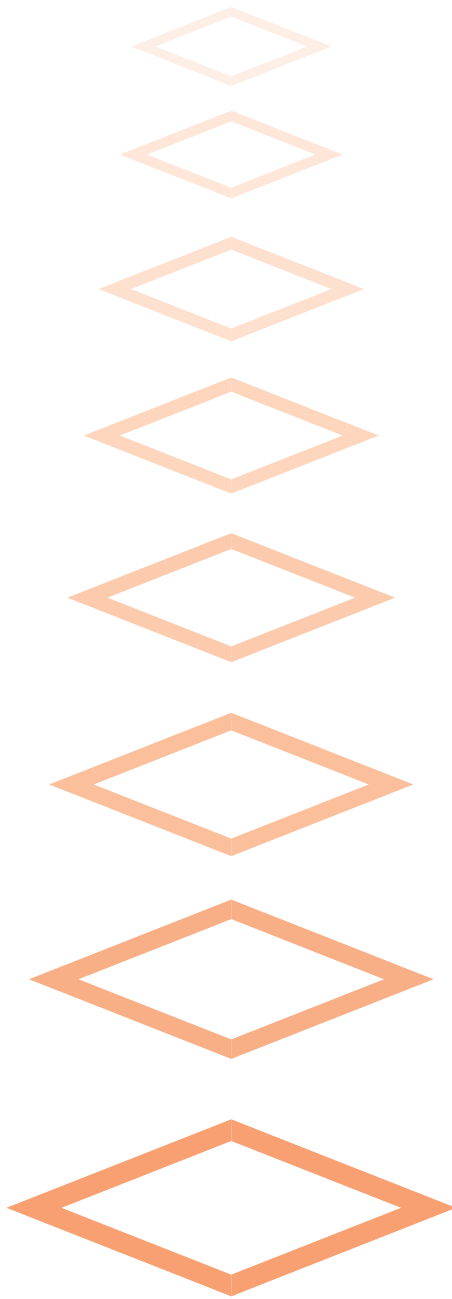

CAN-AM

Challenge Us Today!

SUPPLY SERVICES LTD

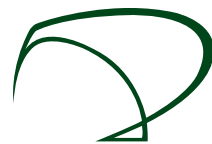

Phone 0800 102 112 - www.supplyservices.co.nz